

WINDSHIELD WIPERS AND WASHERS

CONTENTS

	page		page
GENERAL INFORMATION		WASHER RESERVOIR	8
MULTI-FUNCTION SWITCH	1	WASHER RESERVOIR PUMP	8
WINDSHIELD WASHERS	2	WIPER ARM AND BLADE	9
DESCRIPTION AND OPERATION		WIPER ARM LINKAGE OR CAP	10
WINDSHIELD WASHERS	2	WIPER BLADE	9
WIPER BLADES	2	WIPER BLADE ELEMENT	9
DIAGNOSIS AND TESTING		WIPER MOTOR	10
MULTI-FUNCTION SWITCH – WINDSHIELD		WIPER MOTOR ASSEMBLY	10
WIPER	3	WIPER MOTOR ASSEMBLY MOUNTING	
WINDSHIELD WASHERS	3	GROMMET	10
WINDSHIELD WIPER SYSTEM CONDITIONS ..	3	CLEANING AND INSPECTION	
WIPER MOTOR SYSTEM	6	WIPER BLADES	11
REMOVAL AND INSTALLATION		ADJUSTMENTS	
MULTI-FUNCTION SWITCH	7	WIPER ARM	11
WASHER NOZZLE	7		

GENERAL INFORMATION

MULTI-FUNCTION SWITCH

WARNING: VEHICLES ARE EQUIPPED WITH AN AIRBAG, REFER TO GROUP 8M, RESTRAINT SYSTEMS FOR STEERING WHEEL OR COLUMN SERVICE PROCEDURES.

The multi-function switch (Fig. 1) contains:

- Turn signals
- Hazard warning
- Headlamps
- Headlamp beam select
- Parking lamps
- Panel dimmer
- Fog Lamp
- Headlamp optical horn
- Windshield wiper
- Pulse wipe
- Mist wipe
- Windshield washer switches.

The multi-function switch is mounted center of the steering column. There are two levers, one on each side of the steering column. The left side controls the signaling and lighting. The right side controls the windshield wiper and washer system. To use the washers pull lever toward the driver. The mist is a single wipe operation by pushing lever down and releasing the lever. Intermittent wiper operation is

controlled by the Body Control Module (BCM). The lever has a selection of delay intervals and by turning the lever the wiper will cycle every half second to 36 seconds depending ON the vehicle's speed. The wiper has two cycle two speeds.

The windshield wipers will only operate when the ignition switch is in the ACCESSORY or IGNITION RUN position. Fuse 15, located in the Junction Block, fuses 8 and 14 in the Power Distribution Center (PDC) block, protects the wiper/washer system circuitry. The wiper motor also has an internal non-serviceable circuit breaker to provide protection against motor stall conditions.

The wiper and washer motors have magnetic fields created by internal permanent magnet. Electric power applied to the motor armature, located in the magnetic field, causes the motor to turn.

The wiper system internal operation uses the low speed motor circuit in combination with intermittent wipe relay. The washer pump motor has one internal circuit and therefore operates at one speed.

The wiper and washer system switch located on the steering column selects the mode of operation of the motors. The switch provides input to the BCM, which in turn operates the two relays. The intermittent wipe relay turns the wiper ON and OFF. The other changes the HIGH/LOW speeds. The switch also provides power to the washer pump motor.

The intermittent wiper system, in addition to low and high speed, has a delay mode. The delay mode

GENERAL INFORMATION (Continued)

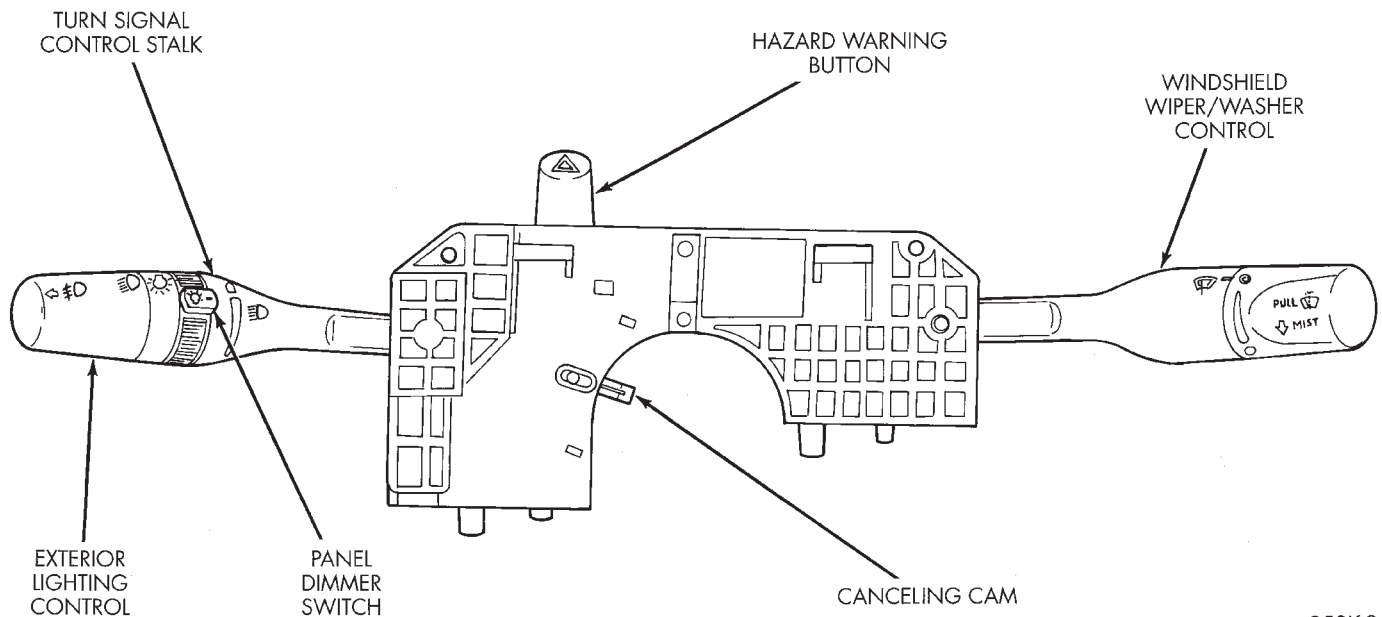

958K-2

Fig. 1 Multi-Function Switch

has a range of 1/2 to 18 seconds when the vehicle speed is over 10 m.p.h.. The wiper delay times will automatically double to a range of 1 to 36 seconds when the vehicle speed is less than 10 m.p.h.. The delay is controlled by a variable resistor in the wiper switch and BCM.

The wiper motor and washer motor are designed to reduce radio frequency interference and provide electro-magnetic compatibility (RFI/EMC) in the vehicle environment. This is done with suppression circuits designed into the motors.

The wiper system completes the wipe cycle when the switch is turned OFF. The blades park in the lowest portion of the wipe pattern.

When using a scan tool (DRB) refer to the Body Diagnostic Manual for the procedures.

WINDSHIELD WASHERS

All models are equipped with electric operated windshield washer pumps. The wash function can be accessed in the OFF or ON position of the multi-function wiper control switch.

DESCRIPTION AND OPERATION

WINDSHIELD WASHERS

Pulling the lever towards the driver when the wiper switch is in the OFF position will operate the wipers and washer motor pump continuously until the lever is released. Releasing the lever will stop the washer pump but the wipers will complete the current wipe cycle. Followed by an average of two more

wipe cycles (± 1) before the wipers park and the module turns off.

The electric pump assembly is mounted with a grommet directly to the reservoir. Fluid is gravity fed from the reservoir to the motor. The fluid is forced by the pump through rubber hoses to the hood mounted nozzles which direct the fluid streams to the windshield. The hose assembly has two one way flow check valves located just before each hood nozzle. The purpose of the check valves is to improve fluid flow response time and to prevent excessive washer fluid staining the surface of the hood. The hood mounted nozzles evenly distribute washer fluid across the surface of the windshield. The nozzles are not adjustable. The pump and reservoir are serviced as separate assemblies.

WIPER BLADES

When the wiper blade rubber element is exposed to the weather for a long period of time, it tends to lose wiping ability. Periodic cleaning of the wiper blade element is suggested to remove the accumulation of salt and road film. The wiper blades, arms, and windshield should be cleaned with a sponge or cloth and a mild detergent or non-abrasive cleaner. If the blades continue to streak or smear, they should be replaced. The driver and the passenger blade elements are 550 mm in length. Only the driver's side wiper blade has a air foil on it (Fig. 2).

DESCRIPTION AND OPERATION (Continued)

DIAGNOSIS AND TESTING

MULTI-FUNCTION SWITCH – WINDSHIELD WIPER

To test the multi-function windshield wiper switch, refer to Group 8J Turn Signals and Hazard Warning Flashers, for diagnosis and testing of the Multi-Function Switch.

WINDSHIELD WASHERS

Whenever a windshield washer malfunction occurs, first verify that the windshield washer wire harness is properly connected to all connectors before starting normal diagnosis and repair procedures. Refer to Windshield Washer Test table.

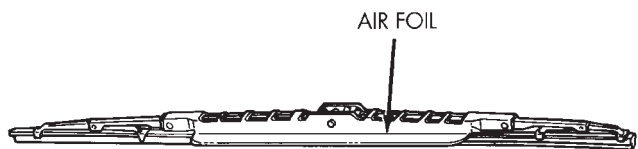

958K-1

Fig. 2 Driver's Wiper Blade

WINDSHIELD WASHER TEST

CONDITION	POSSIBLE CAUSE	CORRECTION
PUMP RUNS NO FLUID FLOWING.	1. NO FLUID IN THE RESERVOIR. 2. NOZZLE PLUGGED OR FROZEN. 3. BROKEN, LOOSE OR PINCHED HOSE. 4. FAULTY PUMP.	1. FILL RESERVOIR. 2. THAW AND CHECK FLOW IF BLOCKED 3. CHECK FLOW THROUGH HOSE CONNECTIONS. 4. APPLY BATTERY VOLTAGE TO MOTOR TERMINALS, REPLACE IF PUMP DOES NOT RUN.
SYSTEM OPERATES INTERMITTENTLY.	1. LOOSE WIRE CONNECTION. 2. FAULTY SWITCH.	1. CHECK WIRE CONNECTIONS. 2. DISCONNECT WIRE HARNESS USE VOLTMETER TO CHECK SWITCH.
SYSTEM OUTPUT IS LOW.	1. PINCHED HOSE. 2. HOSE BLOCKED.	1. CHECK FLOW THROUGH HOSE CONNECTION. 2. DISCONNECT HOSE AT NOZZLE AND Y CONNECTOR CHECK FOR FLOW. REPLACE ASS NECESSARY.

WINDSHIELD WIPER SYSTEM CONDITIONS

The following is a list of general wiper motor system problems and tests that are to be performed to locate the faulty part, and the corrective action to be taken. These tests will cover both two speed and intermittent wiper functions.

Actuation of the wiper relays can be performed using ACTUATOR TESTS on the DRB III. Status of the wiper park switch can also be monitored.

MOTOR WILL NOT RUN IN ANY SWITCH POSITION

(1) Check fuse 15, in the Junction Block and fuse 8 and 18 in the Power Distribution Center (Fig. 3) and (Fig. 4). Refer to Group 8W, Wiring Diagrams for pin call outs.

(a) If fuse(s) are OK, go to Step 2.

(b) If fuse(s) are defective, replace and check motor operation in all switch positions.

(c) If motor is still inoperative and the fuse does not blow, go to Step 2.

(d) If replacement fuse blows, go to Step 11.

(2) Disconnect motor wire harness connector.

(3) Check the wiper motor low speed. Using two jumper wires, connect one jumper wire between the battery positive jump start terminal and Pin B on the wiper motor connector (Fig. 5). Connect the other jumper wire to ground and Pin C on the wiper motor connector. Check the wiper motor high speed, connect the positive jumper wire to Pin A on the wiper motor connector. Connect the negative jumper wire to Pin C on the wiper motor connector.

(a) If motor runs, go to Step 4.

(b) If motor does not run, high or low speed replace the wiper motor.

(4) Using a ohmmeter, check for good ground at Pin C of the wiper motor wire harness connector. If OK, replace motor. If not repair the ground circuit as necessary.

DIAGNOSIS AND TESTING (Continued)

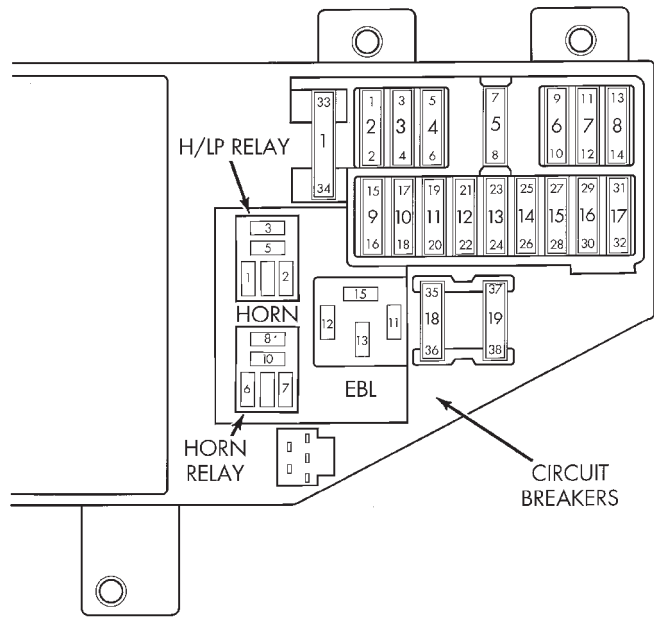

958J-3

Fig. 3 Junction Block

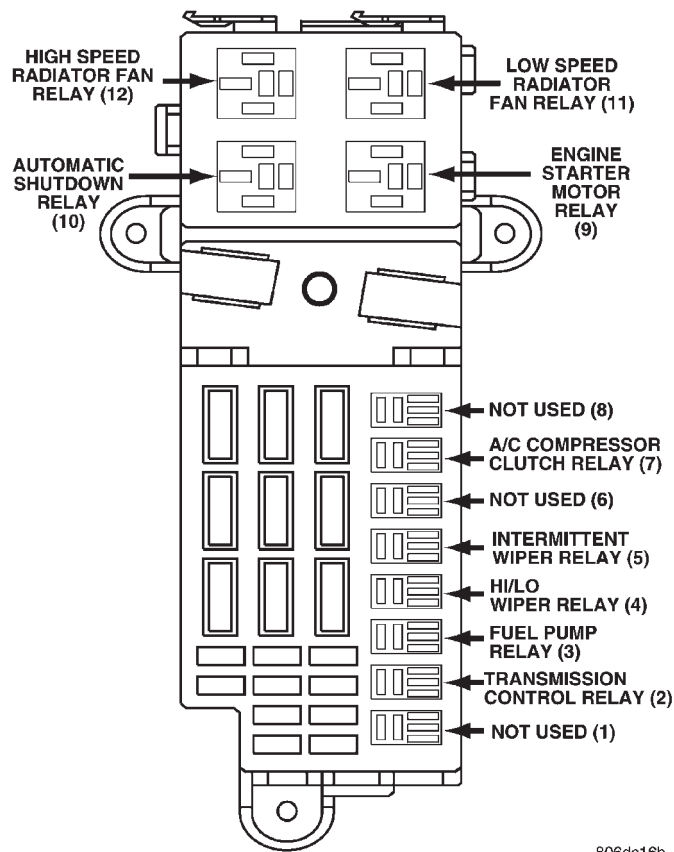

806dc16b

Fig. 4 Power Distribution Center

(5) The wiper switch in the ON position. Using an voltmeter, check for battery voltage at terminal 29 of the intermittent wiper relay in the Power Distribu-

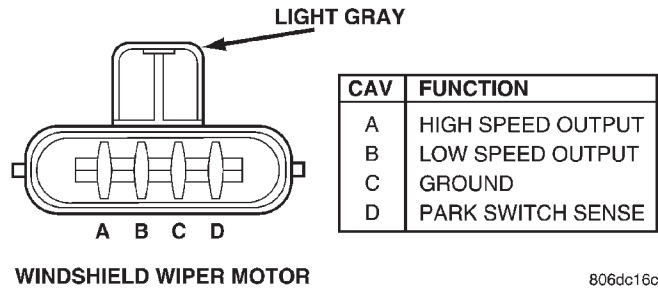

806dc16c

Fig. 5 Motor Wire Connector

tion Center. If no voltage check fuse 18 (Fig. 4). If OK, go to Step 6. If not repair as necessary.

(6) Using an ohmmeter, check from terminal 28 of the HI-LO wiper relay to Pin A of the motor wire connector for continuity. Check from terminal 11 of the HI-LO wiper relay to Pin B of the motor wire connector for continuity. If OK, go to Step 7. If not repair as necessary.

(7) Using an ohmmeter, check for continuity between the HI-LO wiper relay and the intermittent wiper relay. Check from terminal 36 of the HI- LO wiper relay to terminal 37 of the intermittent wiper relay. If OK, check for faulty relays. If not repair as necessary.

(8) Disconnect the J3 14-way connector from the BCM (Fig. 6).

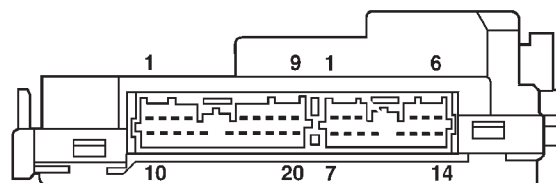

80a7e36e

Fig. 6 Body Control Module 14-Way Connector

(9) Using an ohmmeter, check for continuity from terminal 7 of the J3 14-way connector to the terminal 15 of the intermittent wiper relay. If OK, go to Step 10. If not repair as necessary.

(10) Using a voltmeter, connect positive lead to terminal 10 of the BCM J1 22-way connector and negative lead to ground (Fig. 7). Turn ignition switch to the ON position. Slowly move the wiper switch from OFF position through each position to HIGH.

(a) If voltage increases from zero to approximately 10 volts in the HIGH position, replace BCM. If no voltage, go to Step b.

(b) Using an ohmmeter, check for continuity from terminal 2 of wiper switch connector to terminal 10 of the BCM J3 22-way connector. If no continuity, repair circuit. If OK, go to Step 11.

DIAGNOSIS AND TESTING (Continued)

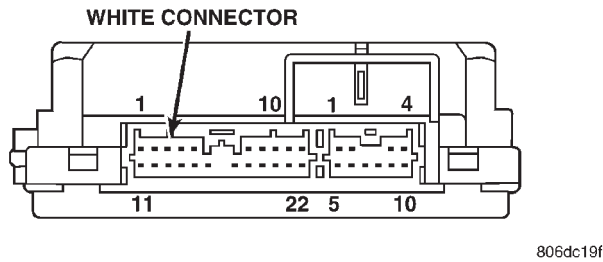

Fig. 7 Body Control Module 22-Way Connector

(11) Disconnect motor connector and replace fuse 15 from the Junction Block.

- (a) If fuse does not blow, go to Step 2.
- (b) If fuse blows, wiper control circuit is at fault, repair as necessary, refer to Group 8W, Wiring Diagrams.

MOTOR RUNS SLOWLY AT ALL SPEEDS

(1) Disconnect the wire harness from the wiper motor. Remove wiper arms and blades. Disconnect motor drive link from motor. Connect an ammeter between battery negative jump start terminal and Pin C on the wiper motor connector (Fig. 5). Connect battery positive wire to Pin B on the wiper motor connector. When replacing drive link nut tighten to 11 to 12 N·m (98 to 106 in. lbs.) torque.

- (a) If average ammeter reading is more than 6 amps, replace motor.
- (b) If motor runs and average ammeter reading is less than 6 amps, go to Step 2.
- (2) Check to see if wiper linkage or pivots are binding or caught.

MOTOR WILL RUN AT HIGH SPEED, BUT NOT MOVE AT LOW SPEED. MOTOR WILL RUN AT LOW SPEED, BUT WILL NOT MOVE AT HIGH SPEED

- (1) Disconnect motor connector.
- (2) If motor will not run on low speed, connect a jumper wire between battery positive jump start terminal and Pin B on the wiper motor connector. Connect a second jumper wire between ground and Pin C on the wiper motor connector (Fig. 5).
 - (a) If motor runs, go to Step 3.
 - (b) If motor does not run, replace the motor.
- (3) If motor will not run on high speed, connect a jumper wire between battery positive remote cable terminal and Pin A. Connect a second jumper wire between ground and Pin C of the motor connector.
 - (a) If motor runs, go to Step 4.
 - (b) If motor does not run, replace the motor.
- (4) If wipers will not run at low speed, using an ohmmeter, check for open circuit. Check between terminal 11 of the HI-LO wiper relay to Pin B of the

wiper motor wire harness connector for continuity. If OK, go to Step 5. If not repair as necessary.

- (5) If wiper will not run at the high speed, using an ohmmeter, check for an open circuit. Check between terminal 28 of the HI-LO wiper relay and Pin A of the wiper motor wire harness connector for continuity. If OK, go to Step 6. If not repair as necessary.
- (6) Check for faulty HI-LO wiper relay.

WIPERS RUN AT HIGH SPEED WITH SWITCH IN LOW SPEED POSITION. WIPERS OPERATE IN INTERMITTENT MODE, BUT EACH WIPE IS AT HIGH SPEED.

- (1) Disconnect motor connector.
- (2) Using two jumper wires, connect one between the battery positive jump start terminal and Pin B on the wiper motor connector. Connect the second lead between ground and Pin C on the wiper motor connector (Fig. 5). If motor runs at low speed, go to Step 3. If motor runs at high speed, replace the motor.
- (3) Check for faulty HI-LO wiper relay. Check for crossed wires in harness from HI-LO relay to motor.
- (4) Disconnect J3 14-way connector from the BCM and remove the intermittent wiper relay.
- (5) Using an ohmmeter, check for short to ground Pin 8 of the J3 14-way connector.
- (6) If continuity to ground is present, repair as necessary. If no continuity to ground, replace the BCM.

WIPERS RUN AT LOW SPEED WITH SWITCH IN HIGH SPEED POSITION

- (1) Check for faulty HI-LO wiper relay.
- (2) Using an ohmmeter, check for open circuit between terminal 12 of the HI-LO wiper relay and terminal 8 of the BCM J3 14-way connector. If OK, go to Step 3. If not OK, repair as necessary.
- (3) Check wiper switch.
- (4) Check for binding linkage
- (5) Refer to MOTOR RUNS SLOWLY AT ALL SPEEDS.

MOTOR WILL KEEP RUNNING WITH SWITCH IN OFF POSITION.

- Using a ohmmeter, Check Pin 8 of the BCM J3 14-way connector for continuity to ground signal when the wipers are in the park position only.
- (1) If no ground signal, test wiper motor.
 - (2) If a ground is received test the multi-function switch.
 - (3) If the multi-function switch test OK, replace the BCM.

DIAGNOSIS AND TESTING (Continued)

WIPER WILL RUN CONTINUOUSLY WITH SWITCH IN THE INTERMITTENT POSITION. WHEN COLUMN SWITCH IS TURNED OFF, WIPERS STOP WHEREVER THEY ARE, WITHOUT RETURNING TO PARK POSITION.

(1) Using an ohmmeter, check for ground at Pin D on the wiper motor connector. If grounded, replace motor.

(2) Using an ohmmeter, with the wiper motor in the PARK position, check for continuity between Pin C and Pin D on the wiper motor connector. If continuous continuity, go to Step 3. If not OK, replace motor.

(3) Disconnect the wiper motor wire harness connector and the J3 14-way connector. Check for continuity between Pin D of the wiper motor wire harness connector and terminal 2 of J3 14-way connector of the BCM. If no continuity, repair as necessary. If continuity is OK, test the wiper motor.

WIPERS DO NOT RUN WHEN WASHER MOTOR IS ENGAGED

(1) Backprobe the J3 14-way connector from the BCM. Refer to Group 8E-Instrument Panel and Systems to access.

(2) Using a voltmeter, connect positive lead to terminal 10 of the 14-way connector and the negative lead to ground.

(3) Engage the washer switch so that the washer motor runs continuously.

(a) If the voltage is zero, check the wiring between the washer motor and the BCM. Repair as necessary.

(b) If the battery voltage, ensure that the 14-way connector is disconnected and check Pin 10 if it has 12 volts. If no voltage replace the BCM. If battery voltage, test for a wiring short refer to Group 8W, Wiring Diagrams.

NOTE: Make sure to test the multi-function switch before replacing the BCM.

WIPERS OPERATE IN INTERMITTENT SETTINGS BUT DOES NOT HAVE SIX DIFFERENT SPEEDS.

To test the multi-function windshield wiper switch, refer to Group 8J, Turn Signals and Hazard Warning Flashers, for diagnosis and testing of the Multi-Function Switch.

WIPER MOTOR SYSTEM

WARNING: ON VEHICLES EQUIPPED WITH AIR-BAGS, SEE GROUP 8M, RESTRAINT SYSTEMS FOR STEERING WHEEL OR COLUMN REMOVAL PROCEDURES.

Whenever a wiper motor malfunction occurs, disconnect motor wire harness and clean the terminals. Ensure the wire harness is properly connected before starting diagnosis and repair procedures. Refer to Wiper Motor Test table.

WIPER MOTOR TEST

CONDITION	POSSIBLE CAUSES	CORRECTION
WIPER BLADES DO NOT PARK PROPERLY	1) WIPER ARMS INPROPERLY PARKED. 2) WIPER ARMS ARE LOOSE ON PIVOT SHAFT. 3) MOTOR CRANK LOOSE AT OUTPUT SHAFT.	1) REMOVE WIPER ARMS AND RUN WIPER MOTOR TO PARK POSITION. REFER TO WIPER ARM REPLACEMENT 2) REMOVE WIPER ARM AND RUN WIPER MOTOR TO PARK POSITION. REFER TO WIPER ARM REPLACEMENT. 3) REMOVE WIPER ARM. RUN WIPER MOTOR TO PARK POSITION AND REMOVE THE MODULE. WITHOUT ROTATING THE MOTOR OUTPUT SHAFT, REMOVE THE CRANK AND CLEAN THE MOTOR SHAFT OF METAL FITTINGS. MOUNT THE MOTOR CRANK ON THE MOTOR SHAFT TOWARD THE MOTOR SO IT CAN SLIDE WITH THE LINKAGE IN THE FULL REVERSAL POSITION. TORQUE TO 25-35 N•m (18-23 ft. lbs.), WITHOUT ROTATING THE MOTOR OUTPUT SHAFT. INSTALL WIPER SYSTEM, REFER TO WIPER MODULE REPLACEMENT.

DIAGNOSIS AND TESTING (Continued)

CONDITION	POSSIBLE CAUSES	CORRECTION
MOTOR STOPS IN ANY POSITION WHEN THE SWITCH IS TURNED OFF	1) OPEN PARK CIRCUIT.	1) CHECK PARK SWITCH BY DISCONNECTING WIRE CONNECTOR AND APPLY BATTERY VOLTAGE TO PIN A. PLACE A JUMPER WIRE FROM PIN B TO PIN C, THEN TO AN EXTERNAL GROUND. REPLACE MOTOR IF IT DOES NOT PARK.
MOTOR WILL NOT STOP WHEN SWITCH IS TURNED OFF	1) FAULTY SWITCH. 2) FAULTY RELAY.	1) CHECK SWITCH IN LOW, HIGH, AND INTERMITTANT POSITION. REPLACE IF NECESSARY. PARK SWITCH MAY BE SHORTED TO GROUND.
WIPER BLADES SLAP AGAINST COWL SCREEN OR WINDOW MOLDINGS	1) WIPER ARMS ARE PARKED INCORRECTLY.) REPAIR WIPER ARMS. REFER TO WIPER ARM REPLACEMENT.
BLADES CHATTER	1) FOREIGN SUBSTANCE SUCH AS POLISH ON GLASS OR BLADES. 2) ARMS TWISTED, BLADE AT WRONG ANGLE ON GLASS. 3) BLADE STRUCTURE BENT. 4) BLADE ELEMENT HAS PERMANENT SET.	1) CLEAN GLASS AND BLADE ELEMENT WITH NON-ABRASIVE CLEANER. 2) REPLACE ARM. 3) REPLACE BLADE. 4) REPLACE BLADE ELEMENT.
WIPER KNOCK AT REVERSAL	1) LINKAGE BUSHINGS WORN. 2) ARMATURE ENDPLAY IN MOTOR.	1) REPLACE WORN LINK. REFER TO WIPER LINKAGE REMOVAL. 2) REPLACE WIPER MOTOR. REFER TO WIPER MOTOR REPLACEMENT.
WIPER MOTOR WILL NOT RUN	1) BLOWN FUSE. 2) NEW FUSE BLOWS AGAIN. 3) NEW FUSE BLOWS AGAIN. 4) NO VOLTAGE AT MOTOR. 5) POOR GROUND.	1) REPLACE FUSE, RUN SYSTEM. 2) CHECK FOR SHORT IN WIRING OR SWITCH. 3) REPLACE FUSE, REMOVE MOTOR CONNECTOR, TURN SWITCH ON, FUSE DOES NOT BLOW, REPLACE MOTOR. 4) CHECK SWITCH AND WIRING. 5) CLEAN GROUND WIRE CONNECTION FROM CORROSION.

REMOVAL AND INSTALLATION

MULTI-FUNCTION SWITCH

REMOVAL

- (1) Disconnect battery negative cable.
- (2) Remove the upper steering column cover. Refer to steering column cover removal procedures below.
- (3) Remove multi-function switch mounting screws (Fig. 8).
- (4) Disconnect wire connectors. Lift the switch straight up to remove.

INSTALLATION

For installation, reverse the above procedures.

- (1) Tighten multi-function switch to column retaining screws to 2.3 N·m (20 in. lbs.) torque.
- (2) Tighten steering column cover retaining screws to 2 N·m (17 in. lbs.) torque.

WASHER NOZZLE

REMOVAL

To replace nozzle, disconnect washer fluid hose. Using a needle nose pliers, squeeze together the locking tabs on the nozzle.

INSTALLATION

For installing make sure that both locking tabs are securely snapped into position. Connect washer fluid

REMOVAL AND INSTALLATION (Continued)

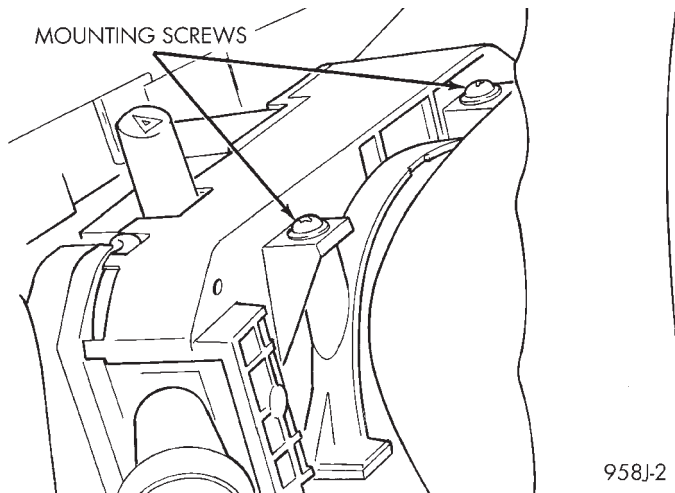
**Fig. 8 Multi-Function Switch**

hose. If no washer spray, check fluid hoses kinks or leaks (Fig. 9).

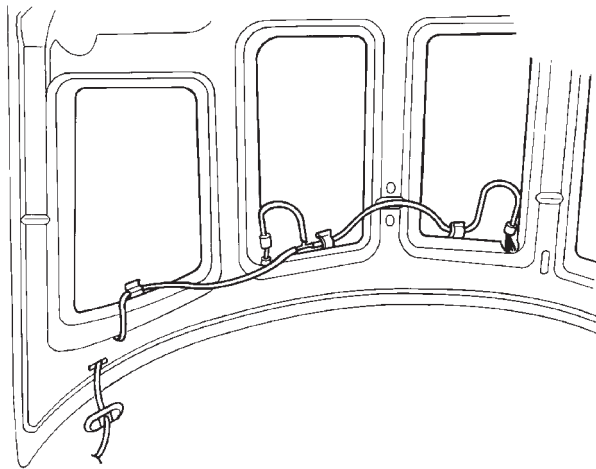
**Fig. 9 Washer Fluid Hose Location****WASHER RESERVOIR****REMOVAL**

- (1) Disconnect washer fluid hose at in-line connector on top of the right shock tower.
- (2) Partially remove bumper fascia as needed to gain access to the reservoir. Refer to Group 23, Body.
- (3) Disconnect wire connector from washer pump and harness mounting tab (Fig. 10).
- (4) Slide rearward and drop down and away from vehicle.
- (5) Drain washer fluid from reservoir into an appropriate container.
- (6) Disconnect the washer hose from the reservoir.

INSTALLATION

For installation, reverse the above procedures.

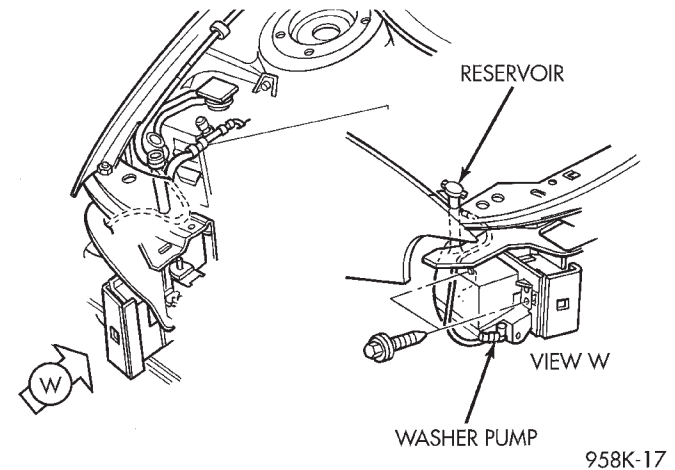
**Fig. 10 Reservoir Removal****WASHER RESERVOIR PUMP****REMOVAL**

- (1) Partially remove the bumper fascia as needed to gain access to the reservoir pump. Refer to Group 23, Body.
- (2) Place a drain bucket below the reservoir to catch any washer solvent that may leak out.
- (3) Firmly grasping pump by hand twist and pull away from reservoir and out of grommet. Care must be taken not to puncture reservoir (Fig. 11).
- (4) Remove rubber grommet from reservoir and throw away.

INSTALLATION

For installation, reverse the above procedures. A new grommet is required for installation. Refill reservoir with the washer solvent.

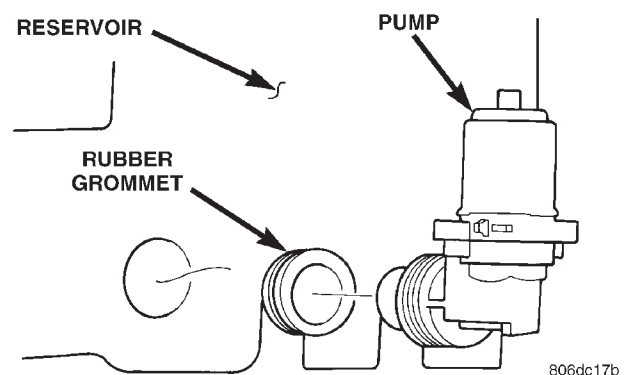
**Fig. 11 Washer Pump**

REMOVAL AND INSTALLATION (Continued)

WIPER ARM AND BLADE

REMOVAL

- (1) Place the wiper arm/blades in the PARK position and turn ignition OFF.
- (2) Unsnap arm cover. By hand rock gently side to side and slide away from arm pivot. To remove the left side raise hood for clearance
- (3) Loosen retention nut.
- (4) Remove the arm from the pivot by using a universal claw puller or by hand rock gently side to side and slide. Raise blade and arm off glass and rock side to side while applying pressure with the puller till loose. Ensure that the puller is not on the collar below the arm.
- (5) Remove arm retention nut and arm.

INSTALLATION

- (1) Place arm on pivot shaft, align blade with wiper location made on windshield
- (2) Start retention nut.
- (3) Raise arm and blade off windshield while tightening retention nut. Tighten nut to 33 to 40 N·mm (23 to 29 ft. lbs.).
- (4) Install arm head cover.

WIPER BLADE

REMOVAL

- (1) Turn wiper switch ON, position blades to a convenient place on the windshield by turning the ignition switch ON and OFF. Turn ignition switch OFF, when blade is in the desirable position.
- (2) Lift wiper arm to raise blade off glass.
- (3) Remove blade assembly from arm by pushing release tab under arm tip and slide blade away from arm tip (Fig. 12) and (Fig. 13).
- (4) The driver's side wiper blade has a air foil on it and the air foil points downward as in (Fig. 2).
- (5) Gently place wiper arm tip on windshield.

INSTALLATION

For installation reverse the above procedures. When complete turn ignition switch ON. Turn wiper switch OFF allowing the wiper blades PARK, then turn ignition switch OFF.

WIPER BLADE ELEMENT

REMOVAL

- (1) Lift wiper arm to raise blade off the windshield.
- (2) Remove blade assembly from arm by pushing release tab under arm tip and slide blade away from arm tip (Fig. 12) and (Fig. 13). Gently place wiper arm tip on windshield.

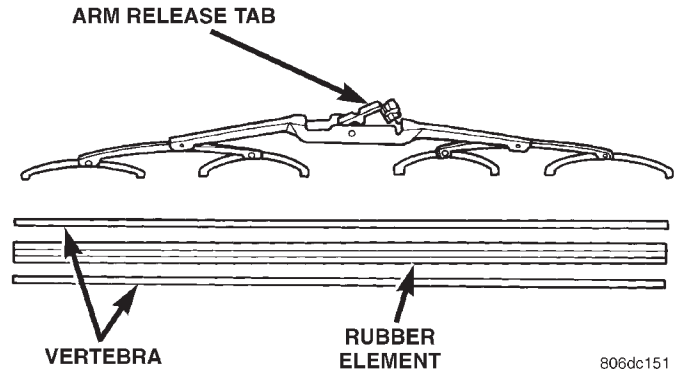

Fig. 12 Wiper Blade and Element

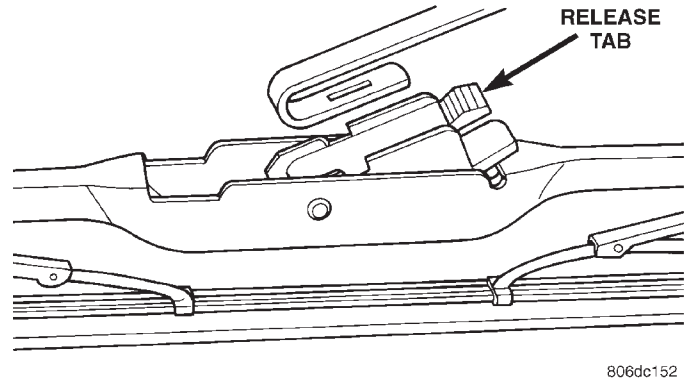

Fig. 13 Remove Blade from Arm

- (3) Remove wiping rubber element by pulling stopper of the rubber element, out of the claws of blade assemble (Fig. 14). The wiper rubber element and two vertebra will be removed.

INSTALLATION

- (1) Slide the rubber element into the blade assembly through the claws.
- (2) Slide the metal vertebra into the top element slot, with the vertebra curved to match the windshield
- (3) Ensure that the final blade claw is locked into the slot at the end of the rubber element (Fig. 14).

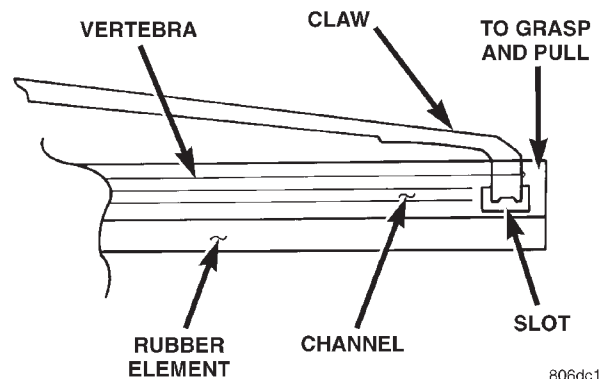

Fig. 14 Wiper Blade and Element

REMOVAL AND INSTALLATION (Continued)

WIPER ARM LINKAGE OR CAP

REMOVAL

- (1) Remove wiper arms and blades.
- (2) Remove the cowl screen.
- (3) Remove wiper motor assembly.
- (4) Disconnect wiper arm linkage, by using a ball joint/tie rod separator, separate the right and left ball cap from the ball (Fig. 15).
- (5) Disconnect drive link from the motor crank. Using an ball joint/tie rod separator and separate the ball cap from the ball.

INSTALLATION

For installation, reverse the above procedures. Align link ball cap over ball and gently press fit against shoulder of cap to lock cap into position. If motor output crank nut was removed, tighten nut to 25 to 30 N·m (19 to 23 ft. lbs.).

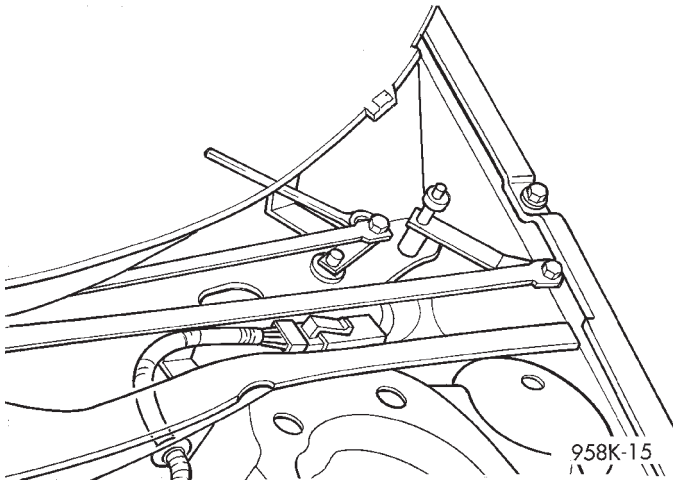

Fig. 15 Linkage Removal

WIPER MOTOR

REMOVAL

- (1) Remove wiper arms and blades.
- (2) Remove the cowl screen.
- (3) Remove wiper motor assembly.
- (4) Disconnect drive linkage from motor output crank. Using an ball joint/tie rod separator, separate the ball cap from the ball (Fig. 15).
- (5) Remove motor mounting nuts and remove motor.
- (6) Disconnect wire connector at motor.

INSTALLATION

For installation, reverse the above procedures. Tighten the mounting screws to 10 to 12 N·m (89 to 106 in. lbs.) torque. Ensure that the motor connector seal is properly positioned. Tighten the motor mounting nuts to 25 to 30 N·m (19 to 23 ft. lbs.) torque.

WIPER MOTOR ASSEMBLY

REMOVAL

- (1) Remove wiper arms and blades (Fig. 16).
- (2) Remove the cowl screen.
- (3) Remove the four wiper motor mounting screws then lift assembly to gain access to clip.
- (4) Disconnect harness clip from the forward mounting leg.
- (5) Disconnect wire connector at motor and remove assembly.

INSTALLATION

For installation, reverse the above procedures. Tighten the mounting screws to 10 to 12 N·m (89 to 106 in. lbs.) torque. Ensure that the motor connector seal is properly positioned.

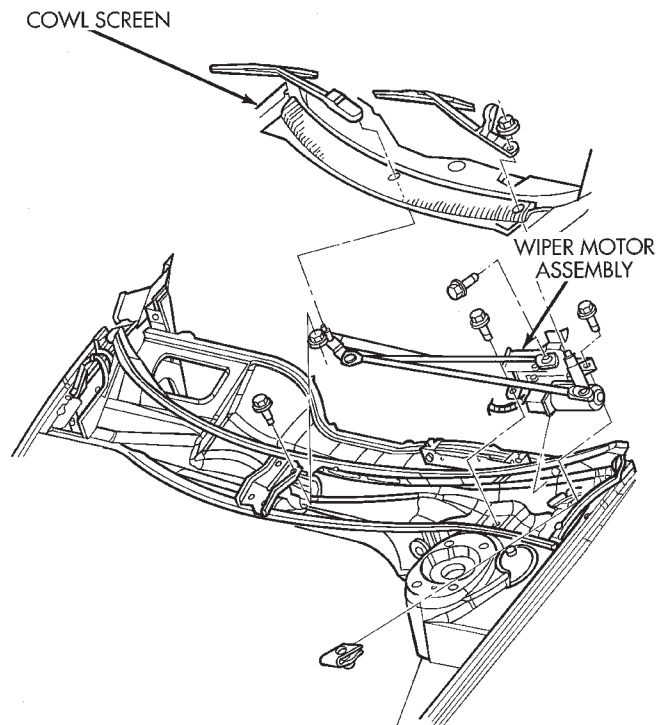

Fig. 16 Wiper Motor and Linkage Module

WIPER MOTOR ASSEMBLY MOUNTING GROMMET

REMOVAL

- (1) Remove wiper arms and blades.
- (2) Remove the cowl screen.
- (3) Remove wiper motor assembly.
- (4) Remove the four grommets.

REMOVAL AND INSTALLATION (Continued)

INSTALLATION

For installation, reverse the above procedures. Ensure proper position of grommets when installing:

- (1) The right inboard grommet is installed with insert flat facing down. The remaining grommets installed with insert flat facing up.
- (2) The left outboard grommet has a small eyelet.
- (3) The right inboard grommet threaded eyelet.
- (4) The two center grommets have a large eyelets

CLEANING AND INSPECTION**WIPER BLADES**

Wiper blades exposed to the weather for a long period of time tend to lose their wiping effectiveness. Periodic cleaning of the wiper blade is recommended to remove the accumulation of salt and road grime. The wiper blades, arms and windshield should be cleaned with a sponge or cloth and a mild detergent or nonabrasive cleaner. If the wiper blades continue to streak or smear, they should be replaced. The wiper blade should run smoothly across the windshield in both directions. The wiper blade should slightly roll over center when the blade reverses direction. A wiper blade insert that has lost flexibility or a wiper arm that has lost spring tension, will cause the blade to skip or chatter across the windshield. If the wiper blades are new and the wiper arm spring tension is OK and a chattering sound is emitted from the wiper(s), the wiper blade is not rolling over center. If this condition exists, refer to the Wiper Arm Alignment paragraph of this group.

ADJUSTMENTS**WIPER ARM**

High speed, wet windshield operation, the right blade tip may override the cowl screen slightly. This is normal and should not affect wiper system performance.

- (1) Lift arms and blade assemble to a over centered position.
- (2) Turn ignition switch to ON or ACC position.
- (3) Use LOW speed setting and cycle the wiper motor to the PARK position.
- (4) Turn ignition OFF.
- (5) Carefully lower arm and blades to the windshield.
- (6) Measure the distance from the blade tip to the cowl screen edge. The blade should be 18 to 42 mm (.75 to 1.60 ins.).
- (7) If not OK, check for worn parts.
- (8) In the event the blade tip strikes the cowl screen or molding remove arm. Position arm on windshield and tighten to 33 to 40 N·m (23 to 29 ft. lbs.) torque (Fig. 17).

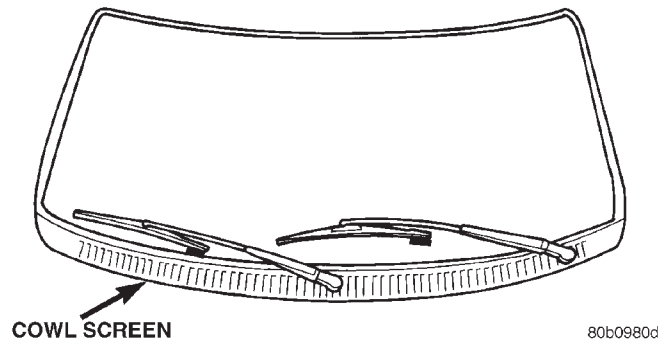

Fig. 17 Arm Adjustment

