

CLUTCH

CONTENTS

	page		page
GENERAL INFORMATION		REMOVAL AND INSTALLATION	
CLUTCH COMPONENTS	1	CLUTCH ASSEMBLY	7
CLUTCH DISC AND COVER APPLICATION	1	CLUTCH CABLE	6
CLUTCH REPLACEMENT	1	CLUTCH PEDAL POSITION SWITCH	7
DESCRIPTION AND OPERATION		RELEASE BEARING AND FORK	8
CLUTCH CABLE	2	CLEANING AND INSPECTION	
CLUTCH PEDAL POSITION SWITCH	2	CLEANING PRECAUTIONS	8
DIAGNOSIS AND TESTING		CLUTCH CONTAMINATION	8
CLASH-INTO-REVERSE COMPLAINTS	5	ADJUSTMENTS	
CLUTCH CHATTER COMPLAINTS	5	CLUTCH CABLE	8
CLUTCH COVER AND DISC RUNOUT	5	CLUTCH PEDAL POSITION SWITCH	9
CLUTCH DIAGNOSIS	3	SPECIFICATIONS	
CLUTCH PEDAL POSITION SWITCH	2	NV T350 (A-578) CLUTCH TIGHTENING	
DRIVE PLATE MISALIGNMENT	5	REFERENCE	9

GENERAL INFORMATION

CLUTCH COMPONENTS

The modular clutch assembly used in this vehicle consists of a single, dry-type clutch disc and a diaphragm style clutch cover. The clutch unit is serviced as an assembly. No disassembly is possible.

The clutch disc has cushion springs riveted to the disc hub assembly. The clutch disc facings are riveted to the cushion springs. The facings are made from a non-asbestos material.

The clutch cover pressure plate assembly is a diaphragm type unit with a one-piece diaphragm spring with multiple release fingers. The pressure plate release fingers are preset during manufacture and are not adjustable.

A sleeve-type release bearing is used to engage and disengage the clutch cover pressure plate. The bearing is prelubed during manufacture and is a sealed unit.

The release bearing is operated by a pivoting release fork in the clutch housing. The fork pivots on a ball stud within the housing. The release fork is actuated by a self-adjusting clutch cable.

The clutch cable has a unique self-adjuster mechanism built into the cable which compensates for clutch disc wear. The cable requires no maintenance or lubrication. There are no serviceable components on the cable assembly.

The clutch pedal is connected to the cable through a plastic spacer. The upper end of the clutch pedal

pivots in the pedal bracket on two nylon bushings and a shaft (Fig. 1). These bushings do not require periodic lubrication.

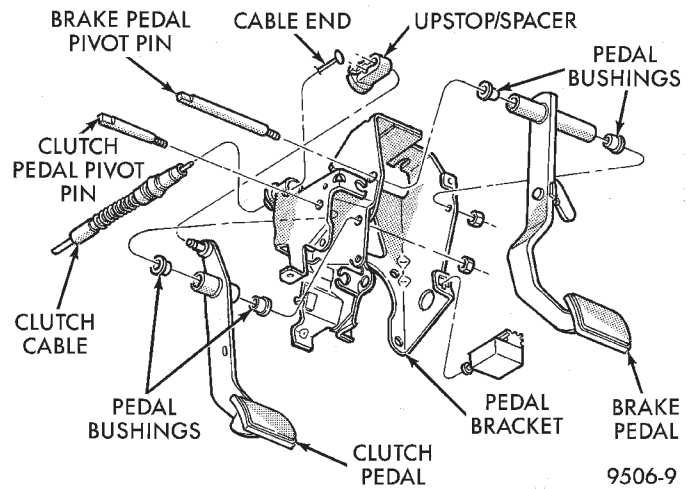

Fig. 1 Clutch Pedal Components

CLUTCH DISC AND COVER APPLICATION

The 2.0 single overhead cam engine uses a 228 mm (9.0 in.) clutch disc. The manual transaxle is available only with the 2.0 liter engine.

CLUTCH REPLACEMENT

The transaxle must be removed to service the modular clutch disc assembly and lever.

DESCRIPTION AND OPERATION

CLUTCH CABLE

The manual transaxle clutch release system has a unique self-adjusting mechanism to compensate for clutch disc wear (Fig. 2). This adjuster mechanism is located within the clutch cable assembly. The preload spring maintains tension on the cable. This tension keeps the clutch release bearing continuously loaded against the fingers of the clutch cover assembly.

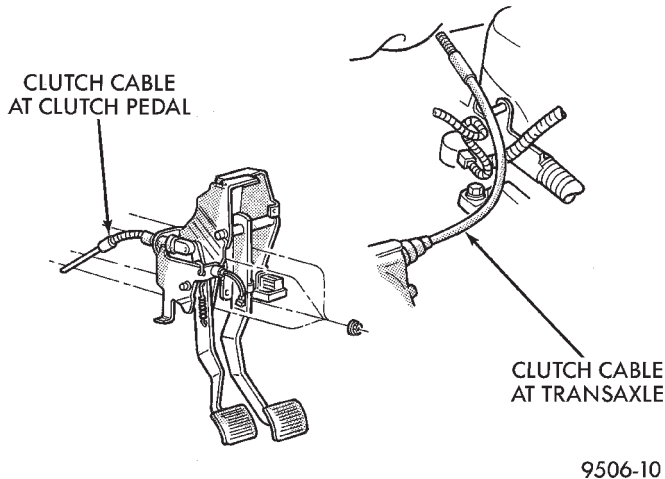

Fig. 2 Clutch Cable Routing

CLUTCH PEDAL POSITION SWITCH

The clutch pedal position switch functions as a safety interlock device. It prevents possible engine cranking with the clutch engaged.

The clutch pedal position switch is wired in series between the starter relay coil and the ignition switch.

The clutch pedal position switch is mounted to a bracket located behind the clutch pedal. The switch is held in place by four plastic wing tabs.

The clutch pedal position switch IS NOT adjustable. The pedal blade contacts the switch in the down position (Fig. 3).

DIAGNOSIS AND TESTING

CLUTCH PEDAL POSITION SWITCH

CLUTCH PEDAL POSITION SWITCH-ELECTRICAL TEST

Disconnect clutch pedal position switch harness from instrument panel wiring harness. Using an ohmmeter, check for continuity between the two terminals in the connector on the switch harness. There

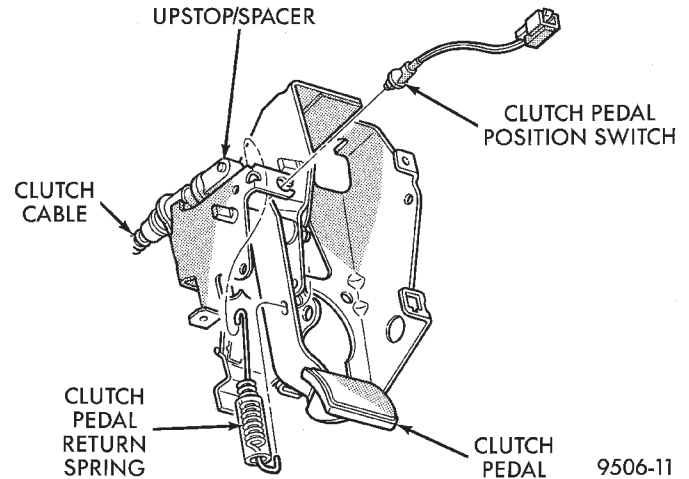

Fig. 3 Clutch Pedal Position Switch and Components

should be no continuity between the terminals when the switch is in its normal (fully extended) position. When the switch is depressed more than 1.25 mm (0.050), the ohmmeter should show continuity (zero ohms).

If ohmmeter readings do not fall within these ranges, the switch is defective, and must be replaced.

CLUTCH PEDAL POSITION SWITCH-MECHANICAL TEST

With the park brake set and the vehicle **IN NEUTRAL**, turn the key to the start position. The vehicle should not crank. If the vehicle cranks, the switch is defective (shorted out) and must be replaced. If the vehicle does not crank proceed to the next step.

WARNING: BEFORE PERFORMING THIS STEP, BE SURE THAT THE AREA IN FRONT OF THE VEHICLE IS CLEAR OF OBSTRUCTIONS AND PEOPLE. VEHICLE MAY MOVE WHEN PERFORMING THIS TEST.

With the park brake set and the vehicle **IN GEAR**, turn the key to the start position and hold it there.

Slowly depress the clutch pedal and feel for any vehicle motion when the starter is energized. If there is no motion the switch is working properly.

If motion is felt, check to see if the switch is making contact when the pedal is between 25 mm (1.0 in.) and 6 mm (0.25 in.) from the floor. If this condition is met, then the problem is either the clutch or the self-adjusting cable (See "Clutch Will Not Disengage Properly"). If this condition is not met, then the switch mounting tab on the brake bracket is bent, and the brake bracket must be replaced.

If vehicle will not crank, even with clutch pedal pressed to the floor, refer to "Service Diagnosis-Clutch Pedal Position Switch" chart in this section.

DIAGNOSIS AND TESTING (Continued)

SERVICE DIAGNOSIS—CLUTCH PEDAL POSITION SWITCH

CONDITION	POSSIBLE CAUSES	CORRECTION
ENGINE WON'T CRANK WHEN CLUTCH PEDAL IS PRESSED TO THE FLOOR	Switch does not have continuity when plunger is depressed 1.25 mm	Defective switch. Replace switch.
	Switch plunger is not depressed when clutch pedal is pushed to the floor	Floor mat interferes with clutch pedal movement. Move floor mat out of the way.
	Problem is related to other components in the starting circuit	Check other components in the starting circuit. Refer to Section 8A, Battery/Starting/Charging System.

CLUTCH DIAGNOSIS

Problem diagnosis will generally require a road test to determine the type of fault. Component inspection will then determine the problem after road testing.

Drive the vehicle at normal speeds during road test. Shift the transaxle through all gear ranges and

observe clutch action. If chatter, grab, slip, or improper release is experienced, remove and inspect the clutch components. If the problem is noise or hard shifting, further diagnosis may be needed. The transaxle or other driveline components may actually be at fault.

SERVICE DIAGNOSIS—CLUTCH GRAB/CHATTER

CONDITION	POSSIBLE CAUSES	CORRECTION
CLUTCH DISC FACING COVERED WITH OIL OR GREASE	Oil leak at engine rear main or transaxle input shaft seal	Correct leak and replace modular clutch assembly
	Too much grease applied to splines of disc and input shaft	Apply lighter coating of grease to splines
NO FAULT FOUND WITH CLUTCH COMPONENTS	Problem actually related to suspension or driveline component	Further diagnosis required. Check engine/transmission mounts, suspension attaching parts and other driveline components as needed.
	Engine related problems	Check EFI and ignition systems
PARTIAL ENGAGEMENT OF CLUTCH DISC	Clutch cover, spring, or release fingers bent, distorted (rough handling, improper assembly)	Replace modular clutch assembly
	Clutch disc damaged or distorted	Replace modular clutch assembly
	Clutch misalignment	Check alignment and runout of flywheel, disc, or cover. Check clutch housing to engine dowels and dowel holes for damage. Correct as necessary.

DIAGNOSIS AND TESTING (Continued)

SERVICE DIAGNOSIS—CLUTCH SLIPS

CONDITION	POSSIBLE CAUSES	CORRECTION
DISC FACING WORN OUT	Normal wear.	Replace modular clutch assembly.
	Driver frequently rides (slips) clutch, results in rapid wear overheating.	Replace modular clutch assembly
	Insufficient clutch cover diaphragm spring tension	Replace modular clutch assembly
CLUTCH DISC FACING CONTAMINATED WITH OIL OR GREASE	Leak at rear main oil seal or transaxle input shaft seal	Replace leaking seals. Replace modular clutch assembly.
	Excessive amount of grease applied to input shaft splines	Apply less grease to input shaft. Replace modular clutch assembly
	Road splash, water entering housing	Seal housing. Inspect modular clutch assembly.
CLUTCH IS RUNNING PARTIALLY DISENGAGED	Release bearing sticking or binding, does not return to normal running position.	Verify that bearing is actually binding. Then, replace bearing and transmission front bearing retainer if sleeve surface is damaged.
	Cable self-adjuster mechanism sticking or binding causing high preload	Verify that self-adjuster is free to move
CLUTCH DISC FACINGS HAVE FRACTURED INTO SMALL PIECES	Driver performs a 5-1 downshift at vehicle speed in excess of 60 miles per hour	Alert driver to problem cause. Replace modular clutch assembly.
	Leak at rear main or transaxle input shaft seal	Replace modular clutch assembly. Replace seal.
	Excessive heat from slippage	Replace modular clutch assembly

SERVICE DIAGNOSIS—IMPROPER CLUTCH RELEASE

CONDITION	POSSIBLE CAUSES	CORRECTION
CLUTCH DISC BINDS ON INPUT SHAFT SPLINES	Clutch disc hub splines damaged during installation	Clean, smooth, and lubricate disc and shaft splines. Replace modular clutch assembly and/or input shaft if splines are severely damaged.
	Input shaft splines rough, damaged.	Clean input shaft splines. Then lube.
	Corrosion or rust formations on splines of input shaft and disc	Clean input shaft splines and disc splines, then lube
CLUTCH DISC RUSTED TO FLYWHEEL AND/OR PRESSURE PLATE	Occurs in vehicles stored or not driven for extended period of time. Also occurs after steam cleaning if vehicle is not used for extended period.	Replace modular clutch assembly
CLUTCH WILL NOT DISENGAGE PROPERLY	Disc bent, distorted during transaxle installation	Replace modular clutch assembly
	Clutch cover diaphragm spring damaged during transaxle installation	Replace modular clutch assembly
	Release fork bent, loose, or damaged	Replace fork if worn or damaged

DIAGNOSIS AND TESTING (Continued)

CONDITION	POSSIBLE CAUSES	CORRECTION
	Clutch cable binding or routed incorrectly	Check and correct cable routing
	Self-adjuster in cable not functioning properly, resulting in excess cable slack	Pull on cable conduit at transaxle (as if disconnecting cable) to check adjuster operation

SERVICE DIAGNOSIS-CLUTCH PEDAL NOISE

CONDITION	POSSIBLE CAUSES	CORRECTION
CLUTCH PEDAL MAKES REPEATED "POP" NOISE IN THE FIRST INCH OF TRAVEL	Self-adjusting mechanism in cable defective	Replace clutch cable
CLUTCH PEDAL SQUEAKS WHEN DEPRESSED TO FLOOR	Pedal bushings worn out or inadequate lubrication	Replace or lubricate bushings
	Clutch pedal return spring worn out	Replace return spring

DRIVE PLATE MISALIGNMENT

Common causes of misalignment are:

- Heat warping
- Mounting drive plate on a dirty crankshaft flange
- Incorrect bolt tightening
- Improper seating on the crankshaft shoulder
- Loose crankshaft bolts

Clean the crankshaft flange before mounting the drive plate. Dirt and grease on the flange surface may misalign the flywheel, causing excessive runout. Use new bolts when mounting drive plate to crankshaft. Tighten drive plate bolts to specified torque only. Over-tightening can distort the drive plate hub causing excessive runout.

CLUTCH COVER AND DISC RUNOUT

Check condition of the clutch cover before installation. A warped cover or diaphragm spring will cause grab and/or incomplete release or engagement. Use care when handling the clutch assembly. Impact can distort the cover, diaphragm spring, and release fingers.

CLUTCH CHATTER COMPLAINTS

For all clutch chatter complaints, do the following:

- (1) Check for loose, misaligned, or broken engine and transmission mounts. If present, they should be corrected at this time. Test vehicle for chatter. If chatter is gone, there is no need to go any further. If chatter persists:
- (2) Check to see if clutch cable routing is correct and operates smoothly.

(3) Check for loose connections in drive train. Correct any problems and determine if clutch chatter complaints have been satisfied. If not:

- (4) Remove transaxle. See Group 21, Manual Transaxle for procedure.
- (5) Check to see if the release bearing is sticky or binding. Replace bearing, if needed.
- (6) Check linkage for excessive wear on the pivot stud and fork fingers. Replace all worn parts.
- (7) Check clutch assembly for contamination (dirt, oil). Replace clutch assembly, if required.
- (8) Check to see if the clutch disc hub splines are damaged. Replace with new clutch assembly, if necessary.
- (9) Check input shaft splines for damage. Replace, if necessary.
- (10) Check for uneven wear on clutch fingers.
- (11) Check for broken clutch cover diaphragm spring fingers. Replace with new clutch assembly, if necessary.

CLASH-INTO-REVERSE COMPLAINTS

All JA NV T350 (A-578) manual transaxles are equipped with a reverse brake. It prevents clash when shifting into reverse, but only if the vehicle is not moving. See Group 21, Transaxle for further diagnosis.

- (1) Depress clutch pedal to floor and hold. After three seconds, shift to reverse. If clash is present, clutch has excessive spin time, and the reverse brake may not be functioning.
- (2) Remove transaxle. See Group 21, Manual Transaxle for procedure.

DIAGNOSIS AND TESTING (Continued)

(3) Check the input shaft spline, clutch disc splines, and release bearing for dry rust. If present, clean rust off and apply a light coat of bearing grease to the input shaft splines. Apply grease on the input shaft splines only where the clutch disc slides. Verify that the clutch disc slides freely along the input shaft spline.

(4) Check to see if the clutch disc hub splines are damaged, and replace with new clutch assembly if required.

(5) Check the input shaft for damaged splines. Replace as necessary.

(6) Check for broken clutch cover diaphragm spring fingers.

(7) Install clutch assembly and transaxle.

REMOVAL AND INSTALLATION

CLUTCH CABLE

REMOVAL

- (1) Pull up and remove Power Distribution Center.
- (2) Remove clutch cable inspection cover.
- (3) Pull back on clutch cable housing and disengage cable from housing (Fig. 4).

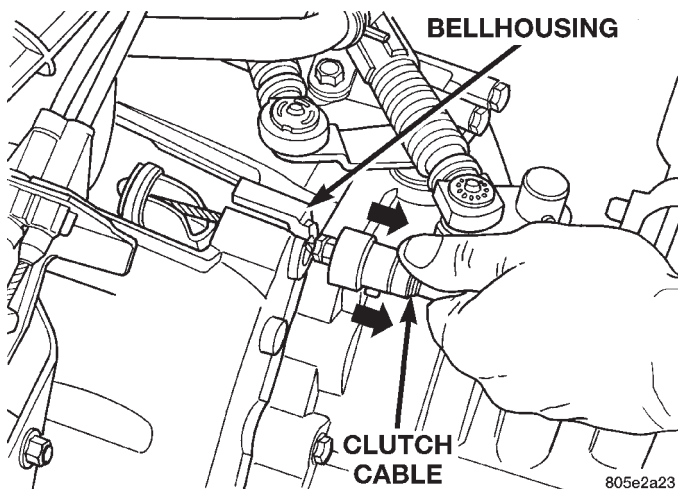

Fig. 4 Cable at Transaxle

(4) Guide cable through slot in transaxle and disconnect cable from release lever.

(5) Disconnect clutch cable up-stop/spacer with cable strand from clutch pedal (Fig. 5).

NOTE: Depressing the clutch pedal provides access to the clutch cable strand. Disconnect the cable up-stop/spacer from the pedal pivot pin by removing the retaining clip at the top of the clutch pedal. Wedge a flat-blade pry tool between the pin and the retaining tab. While holding the tab slightly separated from the pin, pull the upstop/spacer off

the pedal. Now remove the cable end from the upstop/spacer.

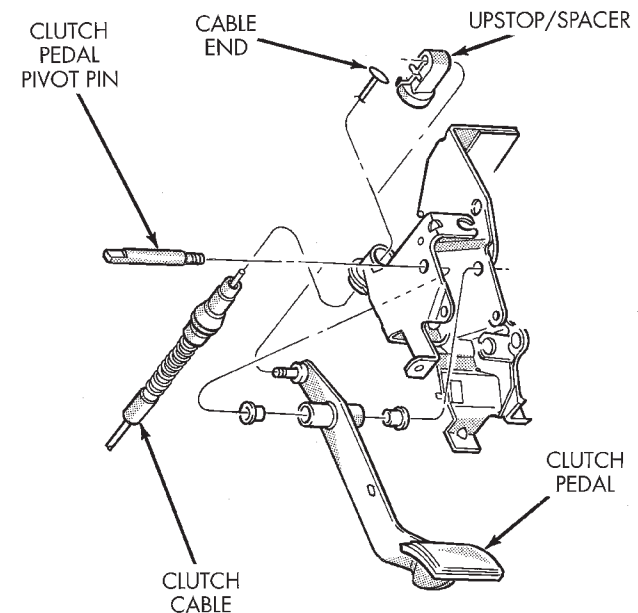

9506-16

Fig. 5 Cable End Removal

CAUTION: Do not pull on the clutch cable to remove it from the dash panel. Damage to the cable self-adjuster may occur.

(6) Use a slight twisting motion while grasping the grommet and body to remove the cable from the dash panel and clutch bracket.

(7) A screwdriver may be required to dislodge the cable grommet from the dash panel. Use caution to avoid damage to the cable grommet.

INSTALLATION

(1) Using a slight twisting motion, insert the self-adjuster mechanism end of the clutch cable through the dash panel hole and into the bracket.

(2) Seat the cylindrical part of the cable grommet in the dash panel. Be sure the self-adjuster is firmly seated against the clutch bracket to ensure proper adjuster mechanism function.

(3) Connect the clutch cable to the up-stop/spacer.

(4) Connect the up-stop/spacer to the clutch pedal.

(5) Perform the Adjuster Mechanism Function Check before finishing installation.

ADJUSTER MECHANISM FUNCTION CHECK

(1) With slight pressure, pull the clutch release lever end of the cable to draw the cable taut. Push the clutch cable housing toward the dash panel (With less than 25 lbs. of effort, the cable housing should move 30-50mm.). This indicates proper adjuster mechanism function. If the cable does not adjust,

REMOVAL AND INSTALLATION (Continued)

determine if the mechanism is properly seated on the bracket.

(2) If the adjust mechanism functions properly, guide the cable through the slot in the transaxle housing. Connect cable to release lever, seating the cupped washer securely on lever tangs.

(3) Pull back on clutch cable housing and insert into transaxle housing (Fig. 4).

(4) Reinstall cable inspection cover and PDC. Check clutch pedal position switch operation.

CLUTCH PEDAL POSITION SWITCH

The clutch pedal position switch is mounted to a bracket located behind the clutch pedal. The switch is held in place by four plastic wing tabs.

The clutch pedal position switch IS NOT adjustable. The pedal blade contacts the switch in the down position (Fig. 6).

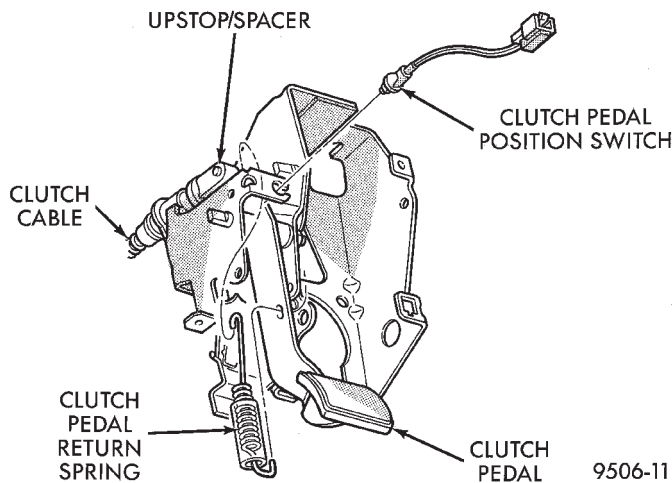

Fig. 6 Clutch Pedal Position Switch and Components

REMOVAL

(1) Disconnect electrical harness to switch connector.

(2) Depress wing tabs on switch and push switch out of mounting bracket. Then slide wires through slot in bracket.

INSTALLATION

(1) Slide switch wires through slot in switch bracket.

(2) Line up switch tab with slot in switch bracket and push switch into position. Do not pull on the switch wires to seat switch into bracket, switch damage may occur.

(3) Attach switch wiring harness to vehicle wiring harness.

(4) After installation, the switch must be checked for proper operation. Refer to Diagnosis and Testing section for proper testing procedures.

CLUTCH ASSEMBLY

The transaxle must be removed to service the modular clutch disc assembly and lever.

REMOVAL

(1) Remove the starter wiring. Remove the starter assembly.

(2) Remove the rear transaxle support bracket.

(3) Remove the front transaxle support bracket.

(4) Remove modular clutch retaining bolts.

(5) Remove transaxle. See Group 21, Manual Transaxle, for procedure.

(6) The transaxle and modular clutch come out as an assembly.

(7) Remove the modular clutch assembly from the transaxle input shaft (Fig. 7). Handle carefully to avoid contaminating the friction surfaces.

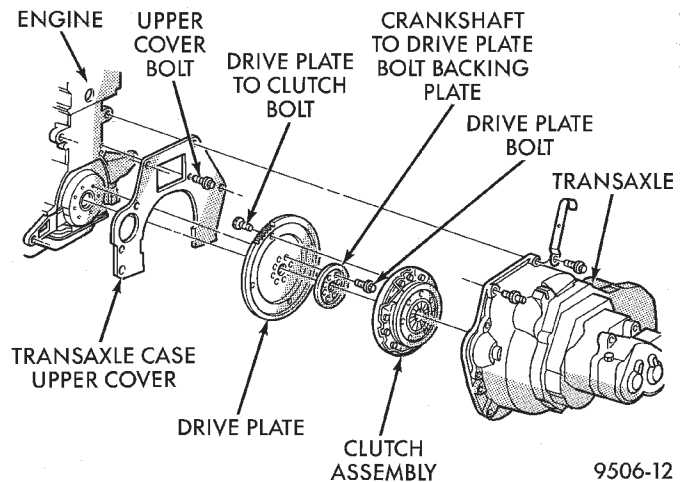

Fig. 7 Clutch Components

INSPECTION

(1) Inspect for oil leakage through engine rear main bearing oil seal and transaxle input shaft seal. If leakage is noted, it should be corrected at this time.

INSTALLATION

(1) Mount modular clutch assembly onto input shaft.

(2) Install transaxle. See Group 21, Manual Transaxle, for procedure.

NOTE: Use new bolts when mounting modular clutch assembly to drive plate.

(3) To avoid distortion of the drive plate, bolts should be tightened a few turns at a time. Use a crisscross pattern, until all bolts are seated. Tighten bolts to 75 N·m (55 ft. lbs.) following a crisscross pattern sequence.

(4) Install clutch inspection cover.

(5) Install transaxle lower support brackets.

(6) Install starter assembly.

REMOVAL AND INSTALLATION (Continued)

RELEASE BEARING AND FORK

Remove the transaxle from the vehicle. See Group 21, Transaxle for removal and installation procedures.

REMOVAL

(1) Move the lever and bearing assembly to a vertical in-line position. Grasp the release lever with two hands in the pivot stud socket area. Pull with even pressure and the lever will pop off the pivot-stud. Do not use a screwdriver or pry bar to pop off the lever. This may damage the spring clip on the lever.

(2) As a unit, remove the fork from the bearing thrust plate. Be careful not to damage retention tabs on bearing.

(3) Examine the condition of the bearing. **It is pre-lubricated and sealed and should not be immersed in oil or solvent.**

(4) The bearing should turn smoothly when held in the hand under a light thrust load. A light drag caused by the lubricant fill is normal. If the bearing is noisy, rough, or dry, replace the complete bearing assembly with a new bearing.

(5) Check the condition of the pivot stud spring clips on back side of clutch fork. If the clips are broken or distorted, replace the clutch fork.

INSTALLATION

(1) The pivot ball pocket in the fork is Teflon coated and should be installed WITHOUT any lubricant such as grease. Using grease will break down the Teflon coating. Be sure the ball stud and fork pocket are clean of contamination and dirt.

(2) Assemble the fork to the bearing. The small pegs on the bearing must go over the fork arms.

(3) Slide the bearing and fork assembly onto the input shaft bearing retainer, as a unit.

(4) Snap the clutch fork onto the pivot ball.

(5) Reinstall transaxle assembly. Refer to Group 21, Transaxle for further information.

CLEANING AND INSPECTION**CLUTCH CONTAMINATION**

Fluid contamination is a frequent cause of clutch malfunctions. Oil, grease, water, or other fluids on the clutch contact surfaces will cause faulty operation.

During inspection, note if any components are contaminated. Look for evidence of oil, grease, or water/road splash on clutch components.

OIL CONTAMINATION

Oil contamination indicates a leak at the rear main seal and/or transaxle input shaft. Oil leaks produce a residue of oil on the transaxle housing interior, clutch cover and flywheel. Heat buildup caused by slippage can bake the oil residue onto the components. This glaze-like residue ranges in color from amber to black.

GREASE CONTAMINATION

Grease contamination is usually a product of over-lubrication. During clutch service, apply only a small amount of grease to the input shaft splines. Excess grease may be thrown off during operation, contaminating the disc.

ROAD SPLASH/WATER CONTAMINATION

Road splash contamination is usually caused by driving the vehicle through deep water puddles. Water can be forced into the clutch housing, causing clutch components to become contaminated. Facing of disc will absorb moisture and bond to the flywheel and/or, pressure plate, if vehicle is allowed to stand for some time before use. If this condition occurs, replacement of clutch assembly may be required. Drive the vehicle until normal clutch operating temperature has been obtained. This will dry off disc assembly, pressure plate, and flywheel.

CLEANING PRECAUTIONS

Condensation from steam vapors tend to accumulate on the internal clutch mechanism when the vehicle is steam cleaned. Facing of disc will absorb moisture and will bond to flywheel and/or pressure plate, if vehicle is allowed to stand for some time before use. If this condition occurs, it may require replacement of clutch assembly. After cleaning, drive the vehicle to its normal clutch operating temperature. This will dry off disc assembly, pressure plate, and flywheel.

ADJUSTMENTS**CLUTCH CABLE**

The manual transaxle clutch release system has a unique self-adjusting mechanism to compensate for clutch disc wear (Fig. 8). This adjuster mechanism is located within the clutch cable assembly. The preload spring maintains tension on the cable. This tension keeps the clutch release bearing continuously loaded against the fingers of the clutch cover assembly.

ADJUSTER MECHANISM FUNCTION CHECK

(1) With slight pressure, pull the clutch release lever end of the cable to draw the cable taut. Push

ADJUSTMENTS (Continued)

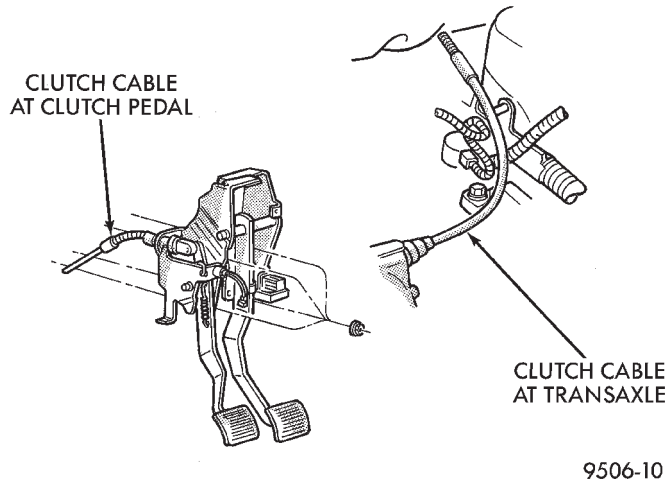

Fig. 8 Clutch Cable Routing

the clutch cable housing toward the dash panel. With less than 25 lbs. of effort the cable housing should move 30-50mm. This indicates proper adjuster mechanism function. If the cable does not adjust, determine if the mechanism is properly seated on the bracket.

(2) If the adjust mechanism functions properly, guide the cable through the slot in the transaxle housing. Connect cable to release lever, seating the cupped washer securely on lever tangs.

(3) Pull back on clutch cable housing and insert into transaxle housing (Fig. 9).

(4) Reinstall cable inspection cover and air cleaner assembly. Check clutch pedal position switch operation.

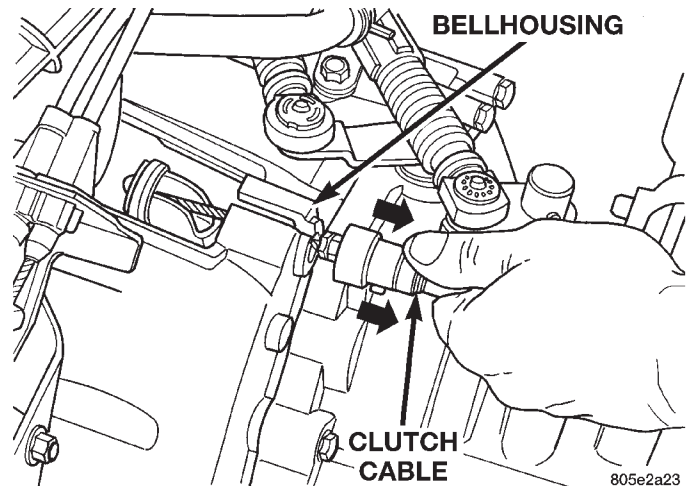

Fig. 9 Cable at Transaxle

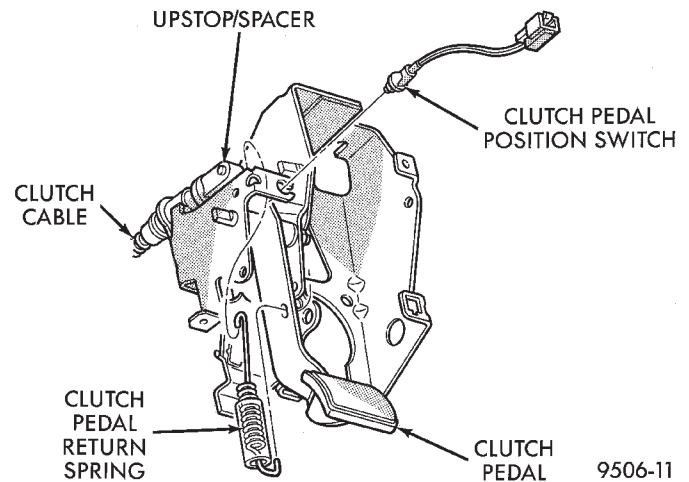

Fig. 10 Clutch Pedal Position Switch and Components

CLUTCH PEDAL POSITION SWITCH

The clutch pedal position switch is mounted to a bracket located behind the clutch pedal. The switch is held in place by four plastic wing tabs.

The clutch pedal position switch IS NOT adjustable. The pedal blade contacts the switch in the down position (Fig. 10).

SPECIFICATIONS

NV T350 (A-578) CLUTCH TIGHTENING REFERENCE

DESCRIPTION	TORQUE
Drive Plate To Clutch Bolts	75 N·m (55 ft. lbs.)
Drive Plate To Crankshaft Bolts	95 N·m (70 ft. lbs.)
Clutch Pedal Pivot Shaft Nut . . .	41 N·m (30 ft. lbs.)

