

LUBRICATION AND MAINTENANCE

CONTENTS

	page	page
JUMP STARTING, TOWING, AND HOISTING	8	MAINTENANCE SCHEDULES 3
LUBRICANTS	1	

LUBRICANTS

INDEX

	page	page	
DESCRIPTION AND OPERATION		PARTS AND LUBRICANT	
CLASSIFICATION OF LUBRICANTS	1	RECOMMENDATIONS	1
FLUID FILL/CHECK LOCATIONS	2	SPECIFICATIONS	
INTERNATIONAL SYMBOLS	2	FLUID CAPACITIES	2
LUBRICATION POINT LOCATIONS	2		

DESCRIPTION AND OPERATION

PARTS AND LUBRICANT RECOMMENDATIONS

DESCRIPTION

When service is required, Chrysler Corporation recommends that only Mopar® brand parts, lubricants and chemicals be used. Mopar provides the best engineered products for servicing Chrysler Corporation vehicles.

CLASSIFICATION OF LUBRICANTS

DESCRIPTION

Only lubricants bearing designations defined by the following organization should be used to service a Chrysler Corporation vehicle.

- Society of Automotive Engineers (SAE)
- American Petroleum Institute (API) (Fig. 1)
- National Lubricating Grease Institute (NLGI) (Fig. 2)

SAE VISCOSITY RATING

An SAE viscosity grade is used to specify the viscosity of engine oil. SAE 30 specifies a single viscosity engine oil. Engine oils also have multiple viscosities. These are specified with a dual SAE viscosity grade which indicates the cold-to-hot temperature viscosity range.

PARTS AND LUBRICANT

RECOMMENDATIONS 1

SPECIFICATIONS

FLUID CAPACITIES 2

- SAE 30 = single grade engine oil.
 - SAE 10W-30 = multiple grade engine oil.
- Chrysler Corporation only recommends multiple grade engine oils.

API QUALITY CLASSIFICATION

This symbol (Fig. 1) on the front of an oil container means that the oil has been certified by the American Petroleum Institute (API) to meet all the lubrication requirements specified by Chrysler Corporation.

Refer to Group 9, Engine for gasoline engine oil specification.



Fig. 1 API Symbol

DESCRIPTION AND OPERATION (Continued)

GEAR LUBRICANTS

SAE ratings also apply to multiple grade gear lubricants. In addition, API classification defines the lubricants usage.

LUBRICANTS AND GREASES

Lubricating grease is rated for quality and usage by the NLGI. All approved products have the NLGI symbol (Fig. 2) on the label. At the bottom NLGI symbol is the usage and quality identification letters. Wheel bearing lubricant is identified by the letter "G". Chassis lubricant is identified by the letter "L". The letter following the usage letter indicates the quality of the lubricant. The following symbols indicate the highest quality.

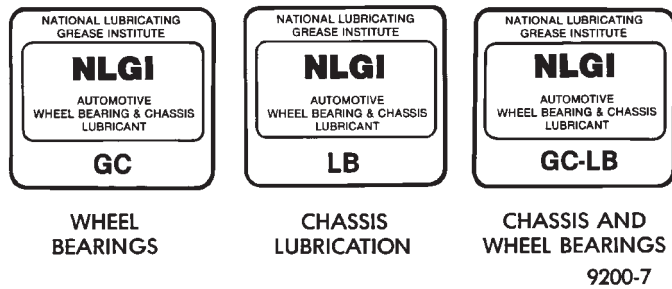

Fig. 2 NLGI Symbol

INTERNATIONAL SYMBOLS

DESCRIPTION

Chrysler Corporation uses international symbols to identify engine compartment lubricant and fluid check and fill locations (Fig. 3).

FLUID FILL/CHECK LOCATIONS

DESCRIPTION

Fluid fill/check locations are located in each applicable group.

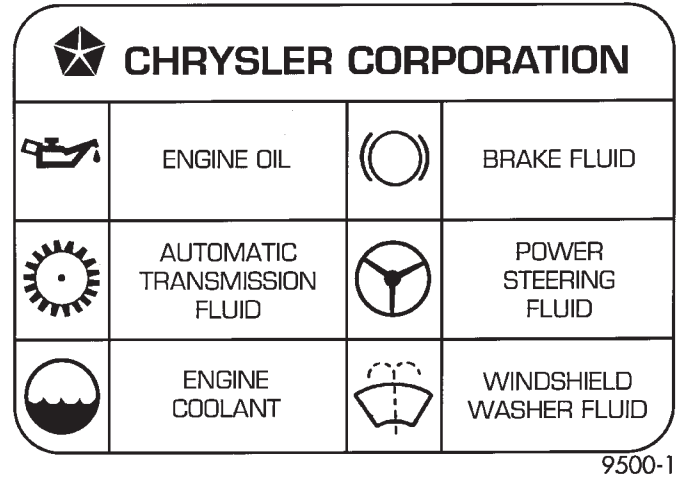

Fig. 3 International Symbols

LUBRICATION POINT LOCATIONS

DESCRIPTION

Lubrication point locations are located in each applicable group.

SPECIFICATIONS

FLUID CAPACITIES

- Fuel Tank 60.5 L (16.0 gal.)
- Engine Oil With Filter – 2.0 L, 2.5 L V6 4.25 L (4.5 qts.)
- Engine Oil With Filter – 2.4 L 4.7 L (5.0 qts.)
- Engine Oil Without Filter – 2.0 L, 2.5 L V6 . . . 3.8 L (4.0 qts.)
- Engine Oil Without Filter – 2.4 L 4.3 L (4.5 qts.)
- Cooling System – 2.0 L 8.1 L (8.5 qts.)
- Cooling System – 2.4 L 8.5 L (9.0 qts.)
- Cooling System – 2.5 L 9.9 L (10.5 qts.)
- Automatic Transaxle - Estimated
 - Service Fill 3.8 L (4.0 qts.)
- Automatic Transaxle - Overhaul Fill
 - Capacity with Torque Converter
 - Empty 8.6 L (9.1 qts.)
- Manual transaxle 2.1 L (2.2 qt.)
- Differential 0.95 L (1 qt.)

MAINTENANCE SCHEDULES

INDEX

	page		page
DESCRIPTION AND OPERATION		SCHEDULE – B	4
MAINTENANCE SCHEDULES	3	UNSCCHEDULE INSPECTION	3
SPECIFICATIONS			
SCHEDULE – A	3		

DESCRIPTION AND OPERATION

MAINTENANCE SCHEDULES

There are two maintenance schedules that show proper service for the vehicle.

Schedule “A”. It lists all the scheduled maintenance to be performed under “normal” operating conditions.

Schedule “B”. It is a schedule for vehicles that are operated under the conditions listed at the beginning of the chart labeled Schedule “B”.

SPECIFICATIONS

UNSCCHEDULE INSPECTION

At Each Stop For Fuel

- Check engine oil level and add as required.
- Check windshield washer solvent and add as required.

Once A Month

- Check tire pressure and look for unusual wear or damage.
- Check fluid levels of coolant reservoir, brake master cylinder, power steering and automatic transmission. Add fluid as required.
- Check all lights and all other electrical items for correct operation.

At Each Oil Change

- Inspect the exhaust system.
- Inspect brake hoses.
- Inspect the CV joints and front suspension component boots and seals.
- Rotate the tires.
- Check the engine coolant level, hoses, and clamps.

If vehicle mileage is less than 7,500 miles (12 000 km) yearly, replace the engine oil filter at each oil change.

EMISSION CONTROL SYSTEM MAINTENANCE

The scheduled emission maintenance listed in **bold type** on the Maintenance Schedules, must be done at the mileage specified to assure the continued proper functioning of the emission control system. These, and all other maintenance services included in this manual, should be done to provide the best vehicle performance and reliability. More frequent maintenance may be needed for vehicles in severe operating conditions such as dusty areas and very short trip driving.

FLUID FILL POINTS AND LUBRICATION LOCATIONS

The fluid fill/check locations and lubrication locations are located in each applicable group.

SCHEDULE – A

7,500 miles (12 000 km) or at 6 months

- Change engine oil.
- Change engine oil filter on 2.0 liter and 2.4 liter engines.

15,000 miles (24 000 km) or at 12 months

- Change engine oil.
- Replace engine oil filter on all engines.
- Adjust drive belt tension.

22,500 Miles (36 000 km) or at 18 months

- Change engine oil.
- Replace engine oil filter on 2.0 liter and 2.4 liter engines.
- Inspect the front brake pads and rear brake linings.

30,000 Miles (48 000 km) or at 24 months

- Change engine oil.
- Replace engine oil filter on all engines.
- Lubricate front and rear suspension upper ball joints.
- Adjust drive belt tension.

SPECIFICATIONS (Continued)

- Replace the **engine air cleaner element (filter)**.

- Replace the **spark plugs** on 2.0 liter and 2.4 liter engines.

- Change the automatic transmission fluid.

37,500 Miles (60 000 km) or at 30 months

- Change engine oil.

- Replace engine oil filter on 2.0 liter and 2.4 liter engines.

45,000 Miles (72 000 km) or at 36 months

- Change engine oil.

- Replace engine oil filter on all engines.

- Inspect front brake pads and rear brake linings.

- Adjust drive belt tension.

- Flush and replace engine coolant at 36 months, regardless of mileage.

52,500 Miles (84 000 km) or at 42 months

- Change engine oil.

- Replace engine oil filter on 2.0 liter and 2.4 liter engines.

60,000 Miles (96 000 km) or at 48 months

- Change engine oil.

- Replace engine oil filter on all engines.

- Check and replace, if necessary, the **PCV valve**.

See note #1 after schedule "B".

- Lubricate front and rear suspension upper ball joints.

- Replace drive belts.

- Replace **engine air cleaner element (filter)**.

- Replace **ignition cables** on 2.0 liter and 2.4 liter engines.

- Replace **spark plugs** on 2.0 liter and 2.4 liter engines.

- Check and adjust if necessary the **ignition timing** on 2.5 liter engines.

- Change the automatic transmission fluid.

67,500 Miles (108 000 km) or at 54 months

- Change engine oil.

- Replace engine oil filter on 2.0 liter and 2.4 liter engines.

- Inspect front brake pads, rear brake linings and rotors.

75,000 Miles (120 000 km) or at 60 months

- Change engine oil.

- Replace engine oil filter on all engines.

- Flush and replace engine coolant.

- Adjust drive belt tension.

82,500 Miles (132 000 km) or at 66 months

- Change engine oil.

- Replace engine oil filter on 2.0 liter and 2.4 liter engines.

90,000 Miles (144 000 km) or at 72 months

- Change engine oil.

- Replace engine oil filter on all engines.

- Check and replace, if necessary, the **PCV valve**. See notes #1 and #2 after Schedule "B".

- Lubricate front and rear suspension upper ball joints.

- Inspect front brake pads, rear brake linings and rotors.

- Adjust drive belt tension.

- Replace **engine air cleaner element (filter)**.

- Replace **spark plugs** on 2.0 liter and 2.4 liter engines.

- Change the automatic transmission fluid.

97,500 Miles (156 000 km) or at 78 months

- Change engine oil.

- Replace engine oil filter on 2.0 liter and 2.4 liter engines.

100,000 Miles (160 000 km) or at 80 months

- Replace **spark plugs and ignition cables** on 2.5 liter engines.

- Replace the engine timing belt on vehicles with 2.0 liter and 2.4 liter engines and Federal emissions package

105,000 Miles (168 000 km) or at 84 months

- Change engine oil.

- Replace engine oil filter on all engines.

- Flush and replace engine coolant.

- Replace **engine timing belt** on 2.0 liter and 2.4 liter engines and California emissions package.

SCHEDULE – B

Follow this schedule if the vehicle usually operates under one or more of the following conditions. Change the automatic transmission fluid and filter every 15,000 miles (24 000 km) if vehicle usually operates under one of the conditions marked with an *.

- Day and night temperatures are below freezing.

- Frequent stop and go driving.*

- Frequent long periods of engine idling.*

- Frequent driving in dusty conditions.

- Frequent short trips of less than 5 miles.

- Frequent operation at sustained high speeds during hot weather, above 90°F (32°C).*

- Frequent trailer towing.*

- Taxi, police or delivery service.*

If vehicle mileage is less than 7,500 miles (12 000 km) yearly, replace the engine oil filter at each oil change.

SPECIFICATIONS (Continued)

3,000 Miles (5 000 km)

- Change engine oil.
- Replace engine oil filter on 2.0 liter and 2.4 liter engines.

6,000 Miles (10 000 km)

- Change engine oil.
- Replace engine oil filter on all engines.

9,000 Miles (14 000 km)

- Change engine oil.
- Replace engine oil filter on 2.0 liter and 2.4 liter engines.

12,000 Miles (19 000 km)

- Change engine oil.
- Replace engine oil filter on all engines.
- Inspect front brake pads, rear brake linings and rotors.

15,000 Miles (24 000 km)

- Change engine oil.
- Replace engine oil filter on 2.0 liter and 2.4 liter engines.

- Adjust drive belt tension.

- Replace **engine air cleaner element (filter)**.

See note #1 after Schedule "B".

- Change automatic transaxle fluid and filter.*

18,000 Miles (29 000 km)

- Change engine oil.
- Replace engine oil filter on all engines.

21,000 Miles (34 000 km)

- Change engine oil.
- Replace engine oil filter on 2.0 liter and 2.4 liter engines.

24,000 Miles (38 000 km)

- Change engine oil.
- Replace engine oil filter on all engines.
- Inspect front brake pads, rear brake linings and rotors.

27,000 Miles (43 000 km)

- Change engine oil.
- Replace engine oil filter on 2.0 liter and 2.4 liter engines.

30,000 Miles (48 000 km)

- Change engine oil.
- Replace engine oil filter on all engines.
- Check and replace, if necessary, the **PCV valve**.

See note #1 after Schedule "B".

- Lubricate front and rear suspension upper ball joints.

- Adjust drive belt tension.

- Replace **engine air cleaner element (filter)** .
- Replace **spark plugs** on 2.0 liter and 2.4 liter engines.

- Change automatic transmission fluid and filter.

33,000 Miles (53 000 km)

- Change engine oil.
- Replace engine oil filter on 2.0 liter and 2.4 liter engines.

36,000 Miles (58 000 km)

- Change engine oil.
- Replace engine oil filter on all engines.
- Flush and replace engine coolant.
- Inspect front brake pads, rear brake linings and rotors.

39,000 Miles (62 000 km)

- Change engine oil.
- Replace engine oil filter on 2.0 liter and 2.4 liter engines.

42,000 Miles (67 000 km)

- Change engine oil.
- Replace engine oil filter on all engines.

45,000 Miles (72 000 km)

- Change engine oil.
- Replace engine oil filter on 2.0 liter and 2.4 liter engines.

- Adjust drive belt tension.

- Inspect and replace, if required **engine air cleaner element (filter)** See note #1 after Schedule "B".

- Change automatic transaxle fluid and filter.*

48,000 Miles (77 000 km)

- Change engine oil.
- Replace engine oil filter on all engines.
- Inspect front brake pads, rear brake linings and rotors.

51,000 Miles (82 000 km)

- Change engine oil.
- Replace engine oil filter on 2.0 liter and 2.4 liter engines.

54,000 Miles (86 000 km)

- Change engine oil.
- Replace engine oil filter on all engines.

57,000 Miles (91 000 km)

- Change engine oil.
- Replace engine oil filter on 2.0 liter and 2.4 liter engines.

SPECIFICATIONS (Continued)

60,000 Miles (96 000 km)

- Change engine oil.
- Replace engine oil filter on all engines.
- Check and replace, if necessary, the **PCV valve**.

See notes #1 and #2 after Schedule "B".

- Lubricate front and rear suspension upper ball joints.
- Replace drive belts.
- Replace the **engine air cleaner element (filter)**.
- Replace the **ignition cables** on 2.0 liter and 2.4 liter engines.
- Replace the **spark plugs** on 2.0 liter and 2.4 liter engines.
- Check and adjust if necessary the **ignition timing** on 2.5 liter engines.
- Change automatic transaxle fluid and filter.
- Inspect front brake pads, rear brake linings and rotors.

63,000 Miles (101 000 km)

- Change engine oil.
- Replace engine oil filter on 2.0 liter and 2.4 liter engines.

66,000 Miles (106 000 km)

- Change engine oil.
- Replace engine oil filter on all engines.

69,000 Miles (110 000 km)

- Change engine oil.
- Replace engine oil filter on 2.0 liter and 2.4 liter engines.

72,000 Miles (115 000 km)

- Change engine oil.
- Replace engine oil filter on all engines.
- Inspect front brake pads, rear brake linings and rotors.

75,000 Miles (120 000 km)

- Change engine oil.
- Replace engine oil filter on 2.0 liter and 2.4 liter engines.
- Adjust drive belt tension.
- Inspect and replace if required the **engine air cleaner element (filter)**. See note #1 after Schedule "B".
- Replace the **spark plugs and ignition cables** on 2.5 liter engines.
- Change automatic transaxle fluid and filter.*

78,000 Miles (125 000 km)

- Change engine oil.
- Replace engine oil filter on all engines.

81,000 Miles (130 000 km)

- Change engine oil.
- Replace engine oil filter on 2.0 liter and 2.4 liter engines.
- Flush and replace the engine coolant.

84,000 Miles (134 000 km)

- Change engine oil.
- Replace engine oil filter on all engines.
- Inspect front brake pads, rear brake linings and rotors.

87,000 Miles (139 000 km)

- Change engine oil.
- Replace engine oil filter on 2.0 liter and 2.4 liter engines.

90,000 Miles (144 000 km)

- Change engine oil.
 - Replace engine oil filter on all engines.
 - Check and replace, if necessary, the **PCV valve**.
- See notes #1 and #2 after Schedule "B".
- Lubricate front and rear suspension upper ball joints.
 - Adjust drive belt tension.
 - Replace the **engine air cleaner element (filter)**.
 - Change automatic transaxle fluid and filter.
 - Replace the **spark plugs** on 2.0 liter and 2.4 liter engines.

93,000 Miles (149 000 km)

- Change engine oil.
- Replace engine oil filter on 2.0 liter and 2.4 liter engines.

96,000 Miles (154 000 km)

- Change engine oil.
- Replace engine oil filter on all engines.
- Inspect front brake pads, rear brake linings and rotors.

99,000 Miles (158 000 km)

- Change engine oil.
- Replace engine oil filter on 2.0 liter and 2.4 liter engines.
- Replace the engine timing belt on 2.0 liter and 2.4 liter engines (Federal emissions package.)

102,000 Miles (163 000 km)

- Change engine oil.
- Replace engine oil filter on all engines.

105,000 Miles (168 000 km)

- Change engine oil.
- Replace engine oil filter on 2.0 liter and 2.4 liter engines.

SPECIFICATIONS (Continued)

- Adjust drive belt tension.
- Inspect and replace, if required, the **engine air cleaner element (filter)**.
- Replace the **engine timing belt** on 2.0 liter 2.4 liter engines (California emissions package.)
- Change automatic transaxle fluid and filter.*

NOTE: #2 This maintenance is not required if previously replaced.

NOTE: #1 This maintenance is recommended by Chrysler Corporation to the owner but is not required to maintain the emissions warranty.

JUMP STARTING, TOWING, AND HOISTING

INDEX

	page
SERVICE PROCEDURES	
HOISTING RECOMMENDATIONS	10

	page
JUMP STARTING PROCEDURE	8
TOWING RECOMMENDATIONS	9

SERVICE PROCEDURES

JUMP STARTING PROCEDURE

WARNING: REVIEW ALL SAFETY PRECAUTIONS AND WARNINGS IN GROUP 8A, BATTERY/STARTING/CHARGING SYSTEMS DIAGNOSTICS. DO NOT JUMP START A FROZEN BATTERY, PERSONAL INJURY CAN RESULT. DO NOT JUMP START WHEN MAINTENANCE FREE BATTERY INDICATOR DOT IS YELLOW OR BRIGHT COLOR. DO NOT JUMP START A VEHICLE WHEN THE BATTERY FLUID IS BELOW THE TOP OF LEAD PLATES. DO NOT ALLOW JUMPER CABLE CLAMPS TO TOUCH EACH OTHER WHEN CONNECTED TO A BOOSTER SOURCE. DO NOT USE OPEN FLAME NEAR BATTERY. REMOVE METALLIC JEWELRY WORN ON HANDS OR WRISTS TO AVOID INJURY BY ACCIDENTAL ARCING OF BATTERY CURRENT. WHEN USING A HIGH OUTPUT BOOSTING DEVICE, DO NOT ALLOW BATTERY VOLTAGE TO EXCEED 16 VOLTS. REFER TO INSTRUCTIONS PROVIDED WITH DEVICE BEING USED.

CAUTION: When using another vehicle as a booster, do not allow vehicles to touch. Electrical systems can be damaged on either vehicle.

TO JUMP START A DISABLED VEHICLE:

- (1) Raise hood on disabled vehicle and visually inspect engine compartment for:
 - Battery cable clamp condition, clean if necessary.
 - Frozen battery.
 - Yellow or bright color test indicator, if equipped.
 - Low battery fluid level.
 - Generator drive belt condition and tension.
 - Fuel fumes or leakage, correct if necessary.

CAUTION: If the cause of starting problem on disabled vehicle is severe, damage to booster vehicle charging system can result.

- (2) When using another vehicle as a booster source, park the booster vehicle within cable reach.

Turn off all accessories, set the parking brake, place the automatic transmission in PARK or the manual transmission in NEUTRAL and turn the ignition OFF.

- (3) On disabled vehicle, place gear selector in park or neutral and set park brake. Turn off all accessories.

- (4) Connect jumper cables to booster battery. RED clamp to positive terminal (+). BLACK clamp to negative terminal (-). DO NOT allow clamps at opposite end of cables to touch, electrical arc will result. Review all warnings in this procedure.

- (5) On disabled vehicle, connect RED jumper cable clamp to positive (+) terminal. Connect BLACK jumper cable clamp to engine ground as close to the ground cable attaching point as possible (Fig. 1).

- (6) Start the engine in the vehicle which has the booster battery, let the engine idle a few minutes, then start the engine in the vehicle with the discharged battery.

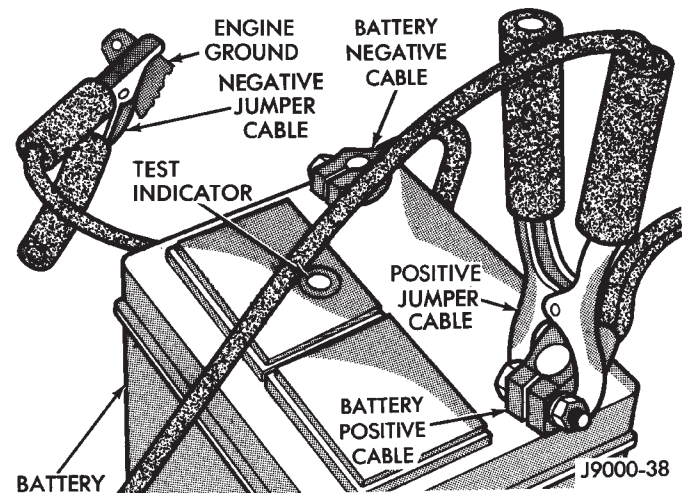

Fig. 1 Jumper Cable Clamp Connections

CAUTION: Do not crank starter motor on disabled vehicle for more than 15 seconds, starter will overheat and could fail.

- (7) Allow battery in disabled vehicle to charge to at least 12.4 volts (75% charge) before attempting to start engine. If engine does not start within 15 sec-

SERVICE PROCEDURES (Continued)

onds, stop cranking engine and allow starter to cool (15 minutes), before cranking again.

DISCONNECT CABLE CLAMPS AS FOLLOWS:

- Disconnect BLACK cable clamp from engine ground on disabled vehicle.
- When using a Booster vehicle, disconnect BLACK cable clamp from battery negative terminal. Disconnect RED cable clamp from battery positive terminal.
- Disconnect RED cable clamp from battery positive terminal on disabled vehicle.

TOWING RECOMMENDATIONS

RECOMMENDED TOWING EQUIPMENT

To avoid damage to bumper fascia and air dams use of a flat bed towing device or wheel lift (Fig. 2) is recommended. When using a wheel lift towing device, be sure the unlifted end of disabled vehicle has at least 100 mm (4 in.) ground clearance. If minimum ground clearance cannot be reached, use a towing dolly. If a flat bed device is used, the approach angle should not exceed 15 degrees.

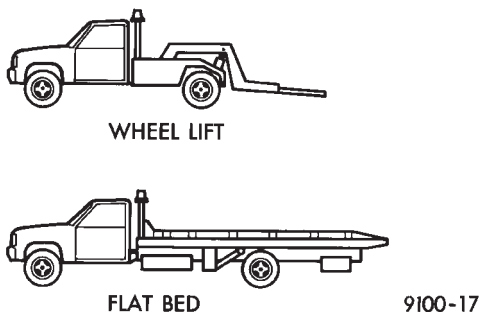

Fig. 2 Recommended Towing Equipment

GROUND CLEARANCE

CAUTION: If vehicle is towed with wheels removed, install lug nuts to retain brake drums or rotors.

A towed vehicle should be raised until the lifted wheels are a minimum 100 mm (4 in.) from the ground. Be sure there is at least 100 mm (4 in.) clearance between the tail pipe and the ground. If necessary, remove the wheels from the lifted end of the vehicle and lower the vehicle closer to the ground, to increase the ground clearance at the rear of the vehicle. Install lug nuts on wheel attaching studs to retain brake drums or rotors.

LOCKED VEHICLE TOWING

When a locked vehicle must be towed with the front wheels on the ground, use a towing dolly or flat bed hauler.

FLAT TOWING WITH TOW BAR

- 3-speed automatic transaxle vehicles can be flat towed at speeds not to exceed 40 km/h (25 mph) for not more than 25 km (15 miles). The steering column must be unlocked and gear selector in neutral.
- 5-speed manual transaxle vehicles can be flat towed at any legal highway speed for extended distances. The gear selector must be in the neutral position.

WARNINGS AND PRECAUTIONS

WARNING: DO NOT ALLOW TOWING ATTACHMENT DEVICES TO CONTACT THE FUEL TANK OR LINES, FUEL LEAK CAN RESULT. DO NOT LIFT OR TOW VEHICLE BY FRONT OR REAR BUMPER, OR BUMPER ENERGY ABSORBER UNITS. DO NOT VENTURE UNDER A LIFTED VEHICLE IF NOT SUPPORTED PROPERLY ON SAFETY STANDS. DO NOT ALLOW PASSENGERS TO RIDE IN A TOWED VEHICLE. USE A SAFETY CHAIN THAT IS INDEPENDENT FROM THE TOWING ATTACHMENT DEVICE.

CAUTION: Do not damage brake lines, exhaust system, shock absorbers, sway bars, or any other under vehicle components when attaching towing device to vehicle. Do not attach towing device to front or rear suspension components. Do not secure vehicle to towing device by the use of front or rear suspension or steering components. Remove or secure loose or protruding objects from a damaged vehicle before towing. Refer to state and local rules and regulations before towing a vehicle. Do not allow weight of towed vehicle to bear on lower fascia, air dams, or spoilers.

FLAT BED TOWING TIE DOWNS

CAUTION: Do not tie vehicle down by attaching chains or cables to suspension components or engine mounts, damage to vehicle can result.

JA vehicles can be tied to a flat bed device using the reinforced loops located under the front and rear bumpers on the drivers side of the vehicle. There are also four reinforced elongated holes for T or R-hooks located on the bottom of the front frame rail torque boxes behind the front wheels and forward of the rear wheels inboard of the rocker panel weld seam.

TOWING—FRONT WHEEL LIFT

Chrysler Corporation recommends that a vehicle be towed with the front end lifted, whenever possible. A 90 cm (36 in.) length of 4x4 wood beam can be placed between the wheel lift device and the bottom of the

SERVICE PROCEDURES (Continued)

fascia to prevent damage to vehicle during the lifting operation. The beam can be removed after lifting the front of the vehicle.

TOWING—REAR WHEEL LIFT

If a vehicle cannot be towed with the front wheels lifted, the rear wheels can be lifted provided the following guide lines are observed.

CAUTION: Do not use steering column lock to secure steering wheel during towing operation.

- Unlock steering column and secure steering wheel in straight ahead position with a clamp device designed for towing.
- Place front wheels on a towing dolly.





HOISTING RECOMMENDATIONS

Refer to Owner's Manual provided with vehicle for proper emergency jacking procedures.

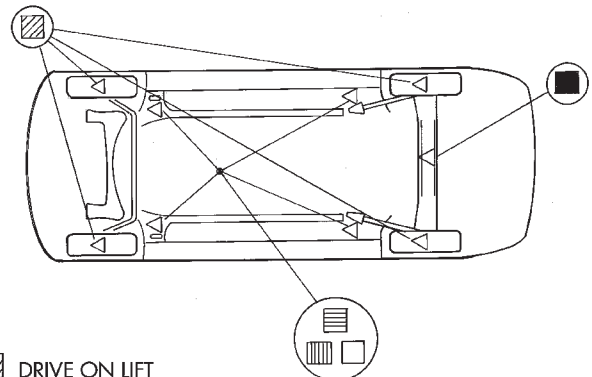
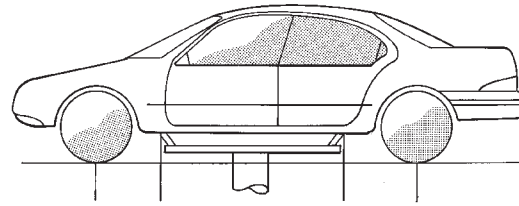
WARNING: THE HOISTING AND JACK LIFTING POINTS PROVIDED ARE FOR A COMPLETE VEHICLE. WHEN THE ENGINE OR REAR SUSPENSION IS REMOVED FROM A VEHICLE, THE CENTER OF GRAVITY IS ALTERED MAKING SOME HOISTING CONDITIONS UNSTABLE. PROPERLY SUPPORT OR SECURE VEHICLE TO HOISTING DEVICE WHEN THESE CONDITIONS EXIST.

CAUTION: Do not position hoisting device on suspension components, damage to vehicle can result.



-  DRIVE ON LIFT
-  FRAME CONTACT LIFT (SINGLE POST)
-  CHASSIS LIFT (DUAL POST)
-  OUTBOARD LIFT (DUAL POST)
-  FLOOR JACK

9500-201x

Fig. 3 Hoisting And Jacking Points