

# LUBRICATION & MAINTENANCE

## TABLE OF CONTENTS

	page		page
<b>LUBRICATION &amp; MAINTENANCE</b>		DESCRIPTION - ENGINE OIL - DIESEL ENGINES	6
SPECIFICATIONS - FLUID CAPACITIES	1	<b>FLUID FILL/CHECK LOCATIONS</b>	
<b>INTERNATIONAL SYMBOLS</b>		DESCRIPTION	6
DESCRIPTION	2	<b>LUBRICATION POINTS</b>	
<b>FLUID TYPES</b>		DESCRIPTION	6
DESCRIPTION		<b>MAINTENANCE SCHEDULES</b>	
DESCRIPTION - ENGINE OIL AND LUBRICANTS	2	DESCRIPTION	6
DESCRIPTION - ENGINE COOLANT	3	<b>HOISTING</b>	
DESCRIPTION - FLEXIBLE FUEL ENGINE OIL	3	STANDARD PROCEDURE - HOISTING	6
DESCRIPTION - AUTOMATIC TRANSMISSION FLUID	4	<b>JUMP STARTING</b>	
DESCRIPTION - FUEL REQUIREMENTS	4	STANDARD PROCEDURE - JUMP STARTING	7
DESCRIPTION - FUEL REQUIREMENTS - DIESEL ENGINE	6	<b>TOWING</b>	
		STANDARD PROCEDURE - TOWING	8

## LUBRICATION & MAINTENANCE

### SPECIFICATIONS - FLUID CAPACITIES







DESCRIPTION	SPECIFICATION
Fuel Tank (Gas)	75 L (20 gal.)
Fuel Tank (Diesel)	75 L (20 gal.)
Engine Oil* - 2.4 L	4.7 L (5.0 qts.)
Engine Oil* - 3.3/3.8 L	4.0 L (4.5 qts.)
Engine Oil* - 2.5 L (Diesel)	6.0 L (6.3 qts.)
Cooling System** - 2.4 L	10.7 L (11.4 qts.)
Cooling System** - 2.5 L Turbo Diesel with Auxiliary Heater	13.8 L (14.6 qts.)
Cooling System** - 3.3/3.8 L without Auxiliary Heater	12.6 L (13.4 qts.)

DESCRIPTION	SPECIFICATION
Cooling System** - 3.3/3.8 L with Auxiliary Heater	15.4 L (16.3 qts.)
Automatic Transaxle - Service Fill	3.8 L (4.0 qts.)
Automatic Transaxle - 31TH Overhaul Fill	8.6 L (9.1 qts.)
Automatic Transaxle - 41TE Overhaul Fill	9.2 L (9.7 qts.)
Manual Transaxle (T850 5-Speed)	2.4-2.7 L (2.5-2.9 qts.)
AWD Power Transfer Unit	1.15 L (2.4 pts.)
Power Steering	1.2 L (2.5 pts.)
AWD Bi-directional Overrunning Clutch	0.575 L (1.22 pts.)
AWD Rear Carrier	0.7 L (1.48 pts.)
* (includes oil filter)	
** (includes heater and recovery/reserve bottle)	

## INTERNATIONAL SYMBOLS

### DESCRIPTION

DaimlerChrysler Corporation uses international symbols to identify engine compartment lubricant and fluid inspection and fill locations (Fig. 1).

	ENGINE OIL		BRAKE FLUID
	AUTOMATIC TRANSMISSION FLUID		POWER STEERING FLUID
	ENGINE COOLANT		WINDSHIELD WASHER FLUID

8097dbcd

Fig. 1 INTERNATIONAL SYMBOLS

## FLUID TYPES

### DESCRIPTION

#### DESCRIPTION - ENGINE OIL AND LUBRICANTS

**WARNING: NEW OR USED ENGINE OIL CAN BE IRRITATING TO THE SKIN. AVOID PROLONGED OR REPEATED SKIN CONTACT WITH ENGINE OIL. CONTAMINANTS IN USED ENGINE OIL, CAUSED BY INTERNAL COMBUSTION, CAN BE HAZARDOUS TO YOUR HEALTH. THOROUGHLY WASH EXPOSED SKIN WITH SOAP AND WATER. DO NOT WASH SKIN WITH GASOLINE, DIESEL FUEL, THINNER, OR SOLVENTS, HEALTH PROBLEMS CAN RESULT. DO NOT POLLUTE, DISPOSE OF USED ENGINE OIL PROPERLY. CONTACT YOUR DEALER OR GOVERNMENT AGENCY FOR LOCATION OF COLLECTION CENTER IN YOUR AREA.**

When service is required, DaimlerChrysler Corporation recommends that only Mopar® brand parts, lubricants and chemicals be used. Mopar® provides the best engineered products for servicing DaimlerChrysler Corporation vehicles.

Only lubricants bearing designations defined by the following organization should be used.

- Society of Automotive Engineers (SAE)
- American Petroleum Institute (API)
- National Lubricating Grease Institute (NLGI)

### API SERVICE GRADE CERTIFIED

Use an engine oil that is API Certified. MOPAR® provides engine oils, that meet or exceed this requirement.

### SAE VISCOSITY

An SAE viscosity grade is used to specify the viscosity of engine oil. Use only engine oils with multiple viscosities such as 5W-30 or 10W-30. These are specified with a dual SAE viscosity grade which indicates the cold-to-hot temperature viscosity range. Select an engine oil that is best suited to your particular temperature range and variation (Fig. 2).

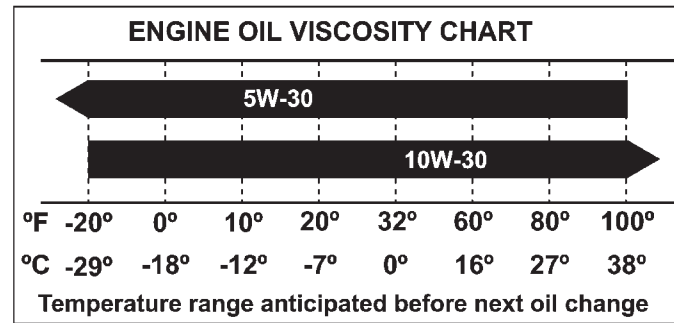

80990199

Fig. 2 TEMPERATURE/ENGINE OIL VISCOSITY

### ENERGY CONSERVING OIL

An Energy Conserving type oil is recommended for gasoline engines. The designation of ENERGY CONSERVING is located on the label of an engine oil container.

### CONTAINER IDENTIFICATION

Standard engine oil identification notations have been adopted to aid in the proper selection of engine oil. The identifying notations are located on the front label of engine oil plastic bottles and the top of engine oil cans (Fig. 3).

This symbol means that the oil has been certified by the American Petroleum Institute (API). DaimlerChrysler only recommend API Certified engine oils. Use Mopar® engine oil or equivalent.

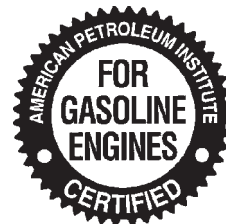

9400-9

Fig. 3 API SYMBOL

FLUID TYPES (Continued)

**GEAR LUBRICANTS**

SAE ratings also apply to multigrade gear lubricants. In addition, API classification defines the lubricants usage. Such as API GL-5 and SAE 75W-90.

**LUBRICANTS AND GREASES**

Lubricating grease is rated for quality and usage by the NLGI. All approved products have the NLGI symbol (Fig. 4) on the label. At the bottom of the NLGI symbol is the usage and quality identification letters. Wheel bearing lubricant is identified by the letter "G". Chassis lubricant is identified by the letter "L". The letter following the usage letter indicates the quality of the lubricant. The following symbols indicate the highest quality.

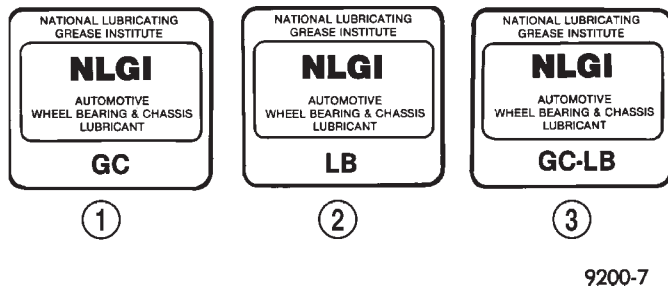

**Fig. 4 NLGI SYMBOL**

- 1 - WHEEL BEARINGS
- 2 - CHASSIS LUBRICATION
- 3 - CHASSIS AND WHEEL BEARINGS

**SPECIALIZED LUBRICANTS AND OILS**

Some maintenance or repair procedures may require the use of specialized lubricants or oils. Consult the appropriate sections in this manual for the correct application of these lubricants.

**DESCRIPTION - ENGINE COOLANT**

**WARNING: ANTIFREEZE IS AN ETHYLENE GLYCOL BASE COOLANT AND IS HARMFUL IF SWALLOWED OR INHALED. IF SWALLOWED, DRINK TWO GLASSES OF WATER AND INDUCE VOMITING. IF INHALED, MOVE TO FRESH AIR AREA. SEEK MEDICAL ATTENTION IMMEDIATELY. DO NOT STORE IN OPEN OR UNMARKED CONTAINERS. WASH SKIN AND CLOTHING THOROUGHLY AFTER COMING IN CONTACT WITH ETHYLENE GLYCOL. KEEP OUT OF REACH OF CHILDREN. DISPOSE OF GLYCOL BASE COOLANT PROPERLY, CONTACT YOUR DEALER OR GOVERNMENT AGENCY FOR LOCATION OF COLLECTION CENTER IN YOUR AREA. DO NOT OPEN A COOLING SYSTEM WHEN THE ENGINE IS AT OPERATING TEMPERATURE OR HOT UNDER PRESSURE, PERSONAL INJURY CAN RESULT. AVOID RADIATOR COOLING FAN WHEN**

**ENGINE COMPARTMENT RELATED SERVICE IS PERFORMED, PERSONAL INJURY CAN RESULT.**

**CAUTION: Use of Propylene Glycol based coolants is not recommended, as they provide less freeze protection and less boiling protection.**

The cooling system is designed around the coolant. The coolant must accept heat from engine metal, in the cylinder head area near the exhaust valves and engine block. Then coolant carries the heat to the radiator where the tube/fin radiator can transfer the heat to the air.

The use of aluminum cylinder blocks, cylinder heads, and water pumps requires special corrosion protection. Mopar® Antifreeze/Coolant, 5 Year/100,000 Mile Formula (MS-9769), or the equivalent ethylene glycol base coolant with hybrid organic corrosion inhibitors (called HOAT, for Hybrid Organic Additive Technology) is recommended. This coolant offers the best engine cooling without corrosion when mixed with 50% Ethylene Glycol and 50% distilled water to obtain a freeze point of -37°C (-35°F). If it loses color or becomes contaminated, drain, flush, and replace with fresh properly mixed coolant solution.

The green coolant **MUST NOT BE MIXED** with the orange or magenta coolants. When replacing coolant the complete system flush must be performed before using the replacement coolant.

**CAUTION: Mopar® Antifreeze/Coolant, 5 Year/100,000 Mile Formula (MS-9769) may not be mixed with any other type of antifreeze. Doing so will reduce the corrosion protection and may result in premature water pump seal failure. If non-HOAT coolant is introduced into the cooling system in an emergency, it should be replaced with the specified coolant as soon as possible.**

**DESCRIPTION - FLEXIBLE FUEL ENGINE OIL**

The information in this section is for Flexible Fuel Vehicles (FFV) only. These vehicles can be identified by the unique Fuel Filler Door Label that states Ethanol (E-85) or Unleaded Gasoline Only. This section only covers those subjects that are unique to these vehicles. Please refer to the other sections of this manual for information on features that are common between Flexible Fuel and gasoline only powered vehicles.

**ETHANOL FUEL (E-85)**

E-85 is a mixture of approximately 85% fuel ethanol and 15% unleaded gasoline.

## FLUID TYPES (Continued)

**WARNING:** Ethanol vapors are extremely flammable and could cause serious personal injury. Never have any smoking materials lit in or near the vehicle when removing the fuel filler tube cap (gas cap) or filling the tank. Do not use E-85 as a cleaning agent and never use it near an open flame.

## FUEL REQUIREMENTS

The vehicle will operate on both unleaded gasoline with an octane rating of 87, or E-85 fuel, or any mixture of these two.

For best results, a refueling pattern that alternates between E-85 and unleaded gasoline should be avoided. When you do switch fuels, it is recommended that

- you do not switch when the fuel gauge indicates less than 1/4 full
- you do not add less than 5 gallons when refueling
- you operate the vehicle immediately after refueling for a period of at least 5 minutes

Observing these precautions will avoid possible hard starting and/or significant deterioration in driveability during warm up.

## FFV STARTING

The characteristics of E-85 fuel make it unsuitable for use when ambient temperatures fall below 0°F. In the range of 0°F to 32°F, you may experience an increase in the time it takes for your engine to start, and a deterioration in driveability (sags and/or hesitations) until the engine is fully warmed up.

## Engine Operating on E-85 Fuel

If vehicle operates on E-85 fuel either full or part-time, use only Mopar® Flexible Fuel 5W-30 engine oil or an equivalent that meets DaimlerChrysler Standard MS-9214. Equivalent commercial Flexible Fuel engine oils may be labeled as Multi-Fuel, Variable Fuel, Flexible Fuel, etc. These engine oils may be satisfactory if they meet the DaimlerChrysler Standard.

SAE 5W-30 engine oil is preferred for use in Flexible Fuel engines.

**CAUTION:** If Flexible Fuel engine oil is not used when using E-85 fuel, engine wear or damage may result.

## CRUISING RANGE

Because E-85 fuel contains less energy per gallon than gasoline, you will experience an increase in fuel consumption. You can expect your MPG and your driving range to decrease by about 30% compared to gasoline operation.

## DESCRIPTION - AUTOMATIC TRANSMISSION FLUID

**NOTE:** Refer to the maintenance schedules for the recommended maintenance (fluid/filter change) intervals for this transaxle.

**NOTE:** All transaxles have a common transmission and differential sump. Filling the transaxle accommodates the differential as well.

## TRANSMISSION FLUID

Mopar® ATF+4 (Automatic Transmission Fluid-Type 9602) is required in the 41TE automatic and T850 manual transaxles. Substitute fluids can induce torque converter clutch shudder.

Mopar® ATF+4 (Automatic Transmission Fluid-Type 9602) when new is red in color. The ATF is dyed red so it can be identified from other fluids used in the vehicle such as engine oil or antifreeze. The red color is not permanent and is not an indicator of fluid condition. As the vehicle is driven, the ATF will begin to look darker in color and may eventually become brown. **This is normal.** ATF+4 also has a unique odor that may change with age. Consequently, **odor and color cannot be used to indicate the fluid condition or the need for a fluid change.**

## FLUID ADDITIVES

DaimlerChrysler strongly recommends against the addition of any fluids to the transmission, other than those automatic transmission fluids listed above. Exceptions to this policy are the use of special dyes to aid in detecting fluid leaks.

Various "special" additives and supplements exist that claim to improve shift feel and/or quality. These additives and others also claim to improve converter clutch operation and inhibit overheating, oxidation, varnish, and sludge. These claims have not been supported to the satisfaction of DaimlerChrysler and these additives **must not be used.** The use of transmission "sealers" should also be avoided, since they may adversely affect the integrity of transmission seals.

## DESCRIPTION - FUEL REQUIREMENTS

Your engine is designed to meet all emissions regulations and provide excellent fuel economy and performance when using high quality unleaded gasoline having an octane rating of 87. The use of premium gasoline is not recommended. The use of premium gasoline will provide no benefit over high quality regular gasoline, and in some circumstances may result in poorer performance.

## FLUID TYPES (Continued)

Light spark knock at low engine speeds is not harmful to your engine. However, continued heavy spark knock at high speeds can cause damage and immediate service is required. Engine damage resulting from operation with a heavy spark knock may not be covered by the new vehicle warranty.

Poor quality gasoline can cause problems such as hard starting, stalling and hesitations. If you experience these symptoms, try another brand of gasoline before considering service for the vehicle.

Over 40 auto manufacturers world-wide have issued and endorsed consistent gasoline specifications (the Worldwide Fuel Charter, WWFC) to define fuel properties necessary to deliver enhanced emissions, performance and durability for your vehicle. We recommend the use of gasolines that meet the WWFC specifications if they are available.

### REFORMULATED GASOLINE

Many areas of the country require the use of cleaner burning gasoline referred to as "reformulated" gasoline. Reformulated gasoline contain oxygenates, and are specifically blended to reduce vehicle emissions and improve air quality.

We strongly support the use of reformulated gasoline. Properly blended reformulated gasoline will provide excellent performance and durability for the engine and fuel system components.

### GASOLINE/OXYGENATE BLENDS

Some fuel suppliers blend unleaded gasoline with oxygenates such as 10% ethanol, MTBE, and ETBE. Oxygenates are required in some areas of the country during the winter months to reduce carbon monoxide emissions. Fuels blended with these oxygenates may be used in your vehicle.

**CAUTION: DO NOT use gasoline containing METHANOL. Gasoline containing methanol may damage critical fuel system components.**

### MMT IN GASOLINE

MMT is a manganese-containing metallic additive that is blended into some gasoline to increase octane. Gasoline blended with MMT provide no performance advantage beyond gasoline of the same octane number without MMT. Gasoline blended with MMT reduce spark plug life and reduce emission system performance in some vehicles. We recommend that gasoline free of MMT be used in your vehicle. The MMT content of gasoline may not be indicated on the gasoline pump; therefore, you should ask your gasoline retailer whether or not his/her gasoline contains MMT.

It is even more important to look for gasoline without MMT in Canada because MMT can be used at

levels higher than allowed in the United States. MMT is prohibited in Federal and California reformulated gasoline.

### SULFUR IN GASOLINE

If you live in the northeast United States, your vehicle may have been designed to meet California low emission standards with Cleaner-Burning California reformulated gasoline with low sulfur. If such fuels are not available in states adopting California emission standards, your vehicles will operate satisfactorily on fuels meeting federal specifications, but emission control system performance may be adversely affected. Gasoline sold outside of California is permitted to have higher sulfur levels which may affect the performance of the vehicle's catalytic converter. This may cause the Malfunction Indicator Lamp (MIL), Check Engine or Service Engine Soon light to illuminate. We recommend that you try a different brand of unleaded gasoline having lower sulfur to determine if the problem is fuel related prior to returning your vehicle to an authorized dealer for service.

**CAUTION: If the Malfunction Indicator Lamp (MIL), Check Engine or Service Engine Soon light is flashing, immediate service is required; see on-board diagnostics system section.**

### MATERIALS ADDED TO FUEL

All gasoline sold in the United States and Canada are required to contain effective detergent additives. Use of additional detergents or other additives is not needed under normal conditions.

### FUEL SYSTEM CAUTIONS

**CAUTION: Follow these guidelines to maintain your vehicle's performance:**

- The use of leaded gas is prohibited by Federal law. Using leaded gasoline can impair engine performance, damage the emission control system, and could result in loss of warranty coverage.
- An out-of-tune engine, or certain fuel or ignition malfunctions, can cause the catalytic converter to overheat. If you notice a pungent burning odor or some light smoke, your engine may be out of tune or malfunctioning and may require immediate service. Contact your dealer for service assistance.
- When pulling a heavy load or driving a fully loaded vehicle when the humidity is low and the temperature is high, use a premium unleaded fuel to help prevent spark knock. If spark knock persists, lighten the load, or engine piston damage may result.

## FLUID TYPES (Continued)

- The use of fuel additives which are now being sold as octane enhancers is not recommended. Most of these products contain high concentrations of methanol. Fuel system damage or vehicle performance problems resulting from the use of such fuels or additives is not the responsibility of DaimlerChrysler Corporation and may not be covered under the new vehicle warranty.

**NOTE:** Intentional tampering with emissions control systems can result in civil penalties being assessed against you.

## DESCRIPTION - FUEL REQUIREMENTS - DIESEL ENGINE

**WARNING: DO NOT USE ALCOHOL OR GASOLINE AS A FUEL BLENDING AGENT. THEY CAN BE UNSTABLE UNDER CERTAIN CONDITIONS AND HAZARDOUS OR EXPLOSIVE WHEN MIXED WITH DIESEL FUEL.**

Use good quality diesel fuel from a reputable supplier. For most year-round service, number 2 diesel fuel meeting ASTM specification D-975 will provide good performance. If the vehicle is exposed to extreme cold (below -18°C/0°F) or is required to operate at colder than normal conditions for prolonged periods, use climatize No. 2 diesel fuel or dilute the No. 2 diesel fuel with 50% No. 1 diesel fuel. This will provide better protection from fuel gelling or wax plugging of the fuel filters.

Diesel fuel is seldom completely free of water. To prevent fuel system trouble, including fuel line freezing in winter, drain the accumulated water from the fuel/water separator using the fuel/water separator drain provided. If you buy good quality fuel and follow the cold weather advice above, fuel conditioners should not be required in your vehicle. If available in your area, a high cetane "premium" diesel fuel may offer improved cold starting and warm up performance.

## DESCRIPTION - ENGINE OIL - DIESEL ENGINES

Use only Diesel Engine Oil meeting standard **MIL-2104C** or API Classification **CD** or **higher** or **CCML D4, D5**.

## SAE VISCOSITY GRADE

**CAUTION:** Low viscosity oils must have the proper API quality or the CCMC G5 designation.

To assure of properly formulated engine oils, it is recommended that SAE Grade 10W-40 engine oils

that meet Chrysler material standard MS-6395, be used. European Grade 10W-40 oils are also acceptable.

Oils of the SAE 5W-40 or 8W-80 grade number are preferred when minimum temperatures consistently fall below -12°C.

## FLUID FILL/CHECK LOCATIONS

## DESCRIPTION

The fluid check/fill point locations are located in each applicable service manual section.

## LUBRICATION POINTS

## DESCRIPTION

Lubrication point locations are located in each applicable Sections.

## MAINTENANCE SCHEDULES

## DESCRIPTION

"Maintenance Schedule Information not included in this section, is located in the appropriate Owner's Manual."

## HOISTING

## STANDARD PROCEDURE - HOISTING

Refer to Owner's Manual provided with vehicle for proper emergency jacking procedures.

**WARNING: THE HOISTING AND JACK LIFTING POINTS PROVIDED ARE FOR A COMPLETE VEHICLE. WHEN THE ENGINE OR REAR SUSPENSION IS REMOVED FROM A VEHICLE, THE CENTER OF GRAVITY IS ALTERED MAKING SOME HOISTING CONDITIONS UNSTABLE. PROPERLY SUPPORT OR SECURE VEHICLE TO HOISTING DEVICE WHEN THESE CONDITIONS EXIST.**

**CAUTION:** Do not position hoisting device on any suspension component, including the front suspension crossmember, the rear leaf springs, and the rear axle. Do not hoist on the front and rear bumpers, the lower liftgate crossmember, the lower radiator crossmember, the down standing flanges on the sill or the front engine mount.

**FOR PROPER HOIST PLACEMENT REFER TO (Fig. 5).**

## HOISTING (Continued)

The hoisting points are identified by S.A.E. inverted triangle hoisting symbols (Fig. 5). The front hoisting points are at the bottom of the front rail below the hoisting symbol approximately 250 mm behind the front suspension crossmember. When using outboard lift hoists, verify that the hoist lift pads have been properly adjusted to eliminate contact between the hoist arm and the down standing flange on the sill. The rear hoisting points are the leaf spring front mounting brackets. The hoist pad must be positioned to pick up the flanges on the bracket, not the leaf spring.

When servicing the leaf springs or the leaf spring mounting brackets, special provisions are required to support the rear of the vehicle. Position the rear hoist pads under the horizontal surface on the bottom of the sill, inboard adjacent to the flange and centered fore/aft between the jacking indicator tabs on the lower flange. **DO NOT HOIST ON THE FLANGE.** Place a soft pad between the hoist and the painted surface on the sill to avoid scratching the finish.

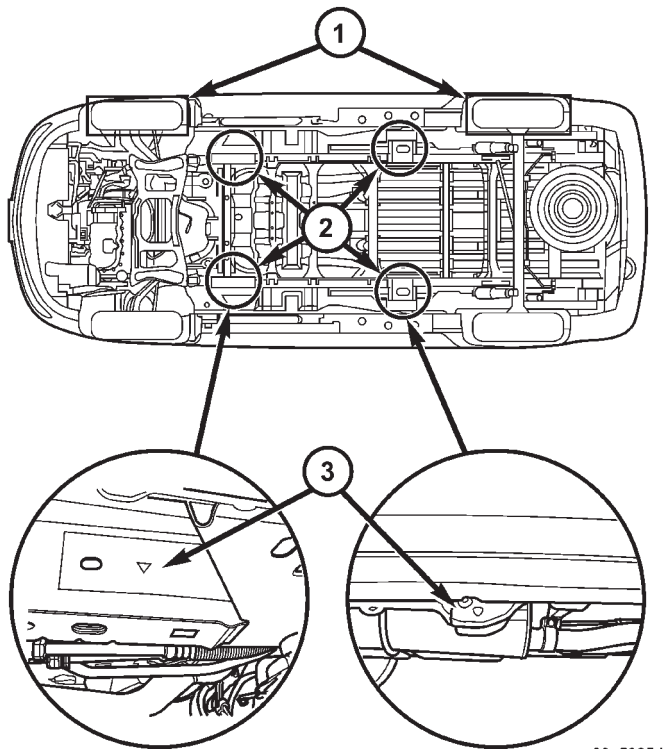

80a5025d

**Fig. 5 HOISTING AND JACKING POINTS**

- 1- DRIVE ON LIFT
- 2 - FRAME CONTACT LIFT (SINGLE POST)
- 2 - CHASSIS LIFT (NON-AXLE DUAL POST)
- 2 - OUTBOARD LIFT (DUAL POST)
- 2 - FLOOR JACK
- 3 - S.A.E. HOISTING SYMBOLS

## JUMP STARTING

## STANDARD PROCEDURE - JUMP STARTING

**WARNING: REVIEW ALL SAFETY PRECAUTIONS AND WARNINGS. (Refer to 8 - ELECTRICAL/BATTERY SYSTEM/BATTERY - STANDARD PROCEDURE).**

**WARNING: DO NOT JUMP START A FROZEN BATTERY, PERSONAL INJURY CAN RESULT.**

**WARNING: DO NOT JUMP START WHEN MAINTENANCE FREE BATTERY INDICATOR DOT IS BRIGHT COLOR.**

**WARNING: DO NOT ALLOW JUMPER CABLE CLAMPS TO TOUCH EACH OTHER WHEN CONNECTED TO A BOOSTER SOURCE.**

**WARNING: DO NOT USE OPEN FLAME NEAR BATTERY**

**WARNING: REMOVE METALLIC JEWELRY WORN ON HANDS OR WRISTS TO AVOID INJURY BY ACCIDENTAL ARCING OF BATTERY CURRENT.**

**WARNING: WHEN USING A HIGH OUTPUT BOOSTING DEVICE, DO NOT ALLOW BATTERY VOLTAGE TO EXCEED 16 VOLTS.**

**WARNING: REFER TO INSTRUCTIONS PROVIDED WITH DEVICE BEING USED.**

**CAUTION: DO NOT ATTEMPT TO PUSH OR TOW THE VEHICLE TO START IT. THE VEHICLE CANNOT BE STARTED THIS WAY. PUSHING WITH ANOTHER VEHICLE MAY DAMAGE THE TRANSAXLE OR THE REAR OF THE VEHICLE.**

(1) Raise hood on disabled vehicle and visually inspect engine compartment for:

- Battery cable clamp condition, clean if necessary.
- Frozen battery.
- Clear or bright color test indicator, if equipped.
- Generator drive belt condition and tension.
- Fuel fumes or leakage, correct if necessary.

**CAUTION: If the cause of starting problem on disabled vehicle is severe, damage to booster vehicle charging system can result.**

## JUMP STARTING (Continued)

(2) When using another vehicle as a booster source, park the booster vehicle within cable reach. Turn off all accessories, set the parking brake, place the automatic transmission in PARK or the manual transmission in NEUTRAL and turn the ignition OFF.

(3) On disabled vehicle, place gear selector in park or neutral and set park brake. Turn off all accessories.

(4) Connect jumper cables to booster battery. RED clamp to positive terminal (+). BLACK clamp to negative terminal (-). DO NOT allow clamps at opposite end of cables to touch, electrical arc will result. Review all warnings in this procedure.

(5) On disabled vehicle, connect RED jumper cable clamp to positive (+) terminal. Connect BLACK jumper cable clamp to engine ground as close to the ground cable attaching point as possible (Fig. 6). (Refer to 8 - ELECTRICAL/BATTERY SYSTEM/BATTERY - STANDARD PROCEDURE).

(6) Start the engine in the vehicle which has the booster battery, let the engine idle a few minutes, then start the engine in the vehicle with the discharged battery.

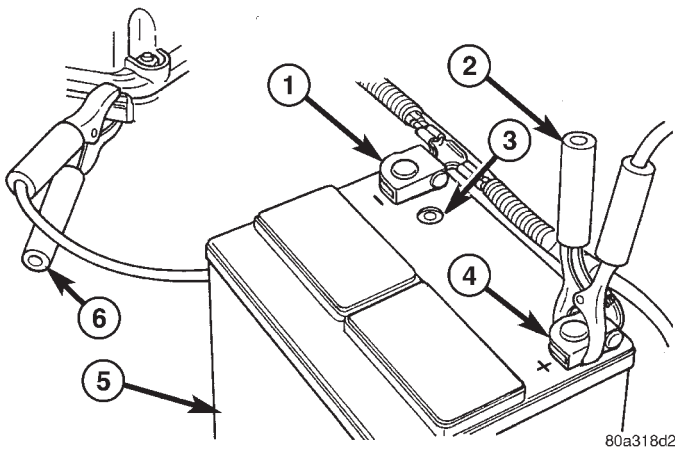

**Fig. 6 JUMPER CABLE CLAMP CONNECTIONS**

- 1 - BATTERY NEGATIVE TERMINAL
- 2 - POSITIVE JUMPER CABLE
- 3 - TEST INDICATOR (IF EQUIPPED)
- 4 - BATTERY POSITIVE TERMINAL
- 5 - BATTERY
- 6 - NEGATIVE JUMPER CABLE

**CAUTION:** Do not crank starter motor on disabled vehicle for more than 15 seconds, starter may over-heat and could fail.

(7) If engine does not start within 15 seconds, stop cranking engine and allow starter to cool (15 minutes), before cranking again.

**DISCONNECT CABLE CLAMPS AS FOLLOWS:**

- Disconnect BLACK cable clamp from engine ground on disabled vehicle.
- When using a Booster vehicle, disconnect BLACK cable clamp from battery negative terminal. Disconnect RED cable clamp from battery positive terminal.
- Disconnect RED cable clamp from battery positive terminal on disabled vehicle.

## TOWING

## STANDARD PROCEDURE - TOWING

## WARNINGS AND CAUTIONS

**WARNING: DO NOT ALLOW TOWING ATTACHMENT DEVICES TO CONTACT THE FUEL TANK OR LINES, FUEL LEAK CAN RESULT.**

**DO NOT LIFT OR TOW VEHICLE BY FRONT OR REAR BUMPER.**

**DO NOT GO UNDER A LIFTED VEHICLE IF NOT SUPPORTED PROPERLY ON SAFETY STANDS.**

**DO NOT ALLOW PASSENGERS TO RIDE IN A TOWED VEHICLE.**

**USE A SAFETY CHAIN THAT IS INDEPENDENT FROM THE TOWING ATTACHMENT DEVICE.**

**CAUTION:** Do not damage brake lines, exhaust system, shock absorbers, sway bars, or any other under vehicle components when attaching towing device to vehicle.

Do not secure vehicle to towing device by the use of front or rear suspension or steering components. Remove or secure loose or protruding objects from a damaged vehicle before towing.

Refer to state and local rules and regulations before towing a vehicle.

Do not allow weight of towed vehicle to bear on lower fascia, air dams, or spoilers.

## RECOMMENDED TOWING EQUIPMENT

To avoid damage to bumper fascia and air dams use:

- FWD vehicles, use of a flat bed towing device or a wheel lift is recommended (Fig. 7).

- AWD vehicles, a flat bed towing device or a wheel lift and towing dolly is recommended (Fig. 7).

When using a wheel lift towing device, be sure the disabled vehicle has at least 100 mm (4 in.) ground clearance. If minimum ground clearance cannot be reached, use a towing dolly. If a flat bed device is used, the approach angle should not exceed 15 degrees.

## TOWING (Continued)

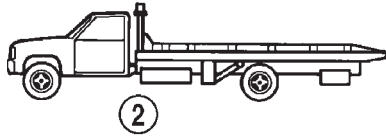
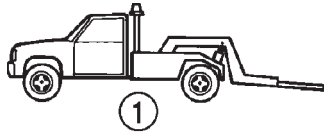

9100-17

**Fig. 7 RECOMMENDED TOWING**

- 1 - WHEEL LIFT  
2 - FLAT BED

**GROUND CLEARANCE**

**CAUTION:** If vehicle is towed with wheels removed, install lug nuts to retain brake drums or rotors.

A towed vehicle should be raised until the lifted wheels are a minimum 100 mm (4 in.) from the ground. Be sure there is at least 100 mm (4 in.) clearance between the tail pipe and the ground. If necessary, remove the wheels from the front end of the vehicle and lower the front end closer to the ground, to increase the ground clearance at the rear of the vehicle. Install lug nuts on wheel attaching studs to retain brake drums or rotors.

**LOCKED VEHICLE TOWING**

When a locked vehicle must be towed with the front wheels on the ground, use a towing dolly or flat bed hauler.

**FLAT TOWING WITH TOW BAR**

- Three speed automatic transaxle vehicles can be flat towed at speeds not to exceed 40 km/h (25 mph) for not more than 25 km (15 miles). The steering column must be unlocked and gear selector in neutral.
- Four speed electronic automatic transaxle vehicles can be flat towed at speeds not to exceed 72 km/h (44 mph) for not more than 160 km (100 miles). The steering column must be unlocked and gear selector in neutral.
- AWD models should not be flat towed. For additional information, refer to **RECOMMENDED TOWING EQUIPMENT** in this section.

**FLAT BED TOWING TIE DOWNS**

**CAUTION:** Do not tie vehicle down by attaching chains or cables to suspension components or engine mounts, damage to vehicle can result.

The vehicle can be tied to a flat bed device using the two pair of front slots on the bottom surface of the rails, behind the front wheels. The two pair of rear slots on the bottom of the rail between the bumper extension bolts and on the bottom of the rail just rearward of the jounce bumper. Vehicles equipped with a rear sway bar have brackets at this location.

**TOWING – FRONT WHEEL LIFT**

If the vehicle is being towed from the front, whenever possible ensure at least 10 inches road clearance to the tires.

**TOWING – REAR WHEEL LIFT**

If a vehicle cannot be towed with the front wheels lifted, the rear wheels can be lifted provided the following guide lines are observed.

**CAUTION:** Do not use steering column lock to secure steering wheel during towing operation.

- On AWD vehicles, all four wheels must be free to rotate. Use towing dollies at unlifted end of vehicle.
- Unlock steering column and secure steering wheel in straight ahead position with a clamp device designed for towing.
- Three speed automatic transaxle vehicles can be flat towed at speeds not to exceed 40 km/h (25 mph) for not more than 25 km (15 miles). The steering column must be unlocked and gear selector in neutral.
- Four speed electronic automatic transaxle vehicles can be flat towed at speeds not to exceed 72 km/h (44 mph) for not more than 160 km (100 miles). The steering column must be unlocked and gear selector in neutral.