

LUBRICATION AND MAINTENANCE

CONTENTS

	page		page
GENERAL INFORMATION	1	MAINTENANCE SCHEDULES	3
JUMP STARTING, HOISTING AND TOWING	7		

GENERAL INFORMATION

INDEX

	page		page
GENERAL INFORMATION		INTRODUCTION	1
CLASSIFICATION OF LUBRICANTS	1	PARTS AND LUBRICANT	
FLUID CAPACITIES	2	RECOMMENDATIONS	1
INTERNATIONAL SYMBOLS	1		

GENERAL INFORMATION

INTRODUCTION

Service and maintenance procedures for components and systems listed in Schedule – A or B can be found by using the Group Tab Locator index at the front of this manual. If it is not clear which group contains the information needed, refer to the index at the back of this manual.

There are two maintenance schedules that show proper service based on the conditions that the vehicle is subjected to.

Schedule – **A**, lists scheduled maintenance to be performed when the vehicle is used for general transportation.

Schedule – **B**, lists maintenance intervals for vehicles that are operated under the conditions listed at the beginning of the Maintenance Schedule section.

Use the schedule that best describes your driving conditions.







Where time and mileage are listed, follow the interval that occurs first.

PARTS AND LUBRICANT RECOMMENDATIONS

When service is required, Chrysler Corporation recommends that only Mopar® brand parts, lubricants and chemicals be used. Mopar provides the best engineered products for servicing Chrysler Corporation vehicles.

INTERNATIONAL SYMBOLS

Chrysler Corporation uses international symbols to identify engine compartment lubricant and fluid inspection and fill locations (Fig. 1).

 CHRYSLER CORPORATION			
	ENGINE OIL		BRAKE FLUID
	AUTOMATIC TRANSMISSION FLUID		POWER STEERING FLUID
	ENGINE COOLANT		WINDSHIELD WASHER FLUID

9500-1

Fig. 1 International Symbols

CLASSIFICATION OF LUBRICANTS

Only lubricants that are endorsed by the following organization should be used to service a Chrysler Corporation vehicle.

- Society of Automotive Engineers (SAE)
- American Petroleum Institute (API) (Fig. 2)
- National Lubricating Grease Institute (NLGI) (Fig. 3)

GENERAL INFORMATION (Continued)



9400-9

Fig. 2 API Symbol

ENGINE OIL

SAE VISCOSITY RATING INDICATES ENGINE OIL VISCOSITY

An SAE viscosity grade is used to specify the viscosity of engine oil. SAE 30 specifies a single viscosity engine oil. Engine oils also have multiple viscosities. These are specified with a dual SAE viscosity grade which indicates the cold-to-hot temperature viscosity range.

- SAE 30 = single grade engine oil.
- SAE 10W-30 = multiple grade engine oil.

API QUALITY CLASSIFICATION

The API Service Grade specifies the type of performance the engine oil is intended to provide. The API Service Grade specifications also apply to energy conserving engine oils.

Use engine oils that are API Service Certified. 5W-30 and 10W-30 MOPAR engine oils conform to specifications.

Refer to Group 9, Engine for engine oil specification.

GEAR LUBRICANTS

SAE ratings also apply to multiple grade gear lubricants. In addition, API classification defines the lubricants usage.

LUBRICANTS AND GREASES

Lubricating grease is rated for quality and usage by the NLGI. All approved products have the NLGI symbol (Fig. 3) on the label. At the bottom NLGI symbol is the usage and quality identification letters. Wheel bearing lubricant is identified by the letter "G". Chassis lubricant is identified by the letter "L". The letter following the usage letter indicates the quality of the lubricant. The following symbols indicate the highest quality.

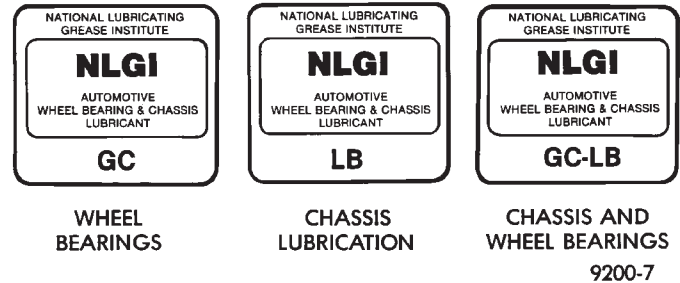

9200-7

Fig. 3 NLGI Symbol

FLUID CAPACITIES

Fuel Tank76 L (20 gal.)
Engine Oil, With Filter43 L (4.5 qts.)
Engine Oil, W/O Filter.38 L (4.0 qts.)
Cooling System 2.4L Engine90 L (9.5 qts.)
Cooling System 3.0L Engine95 L (10.5 qts.)
Cooling System 3.3 or 3.8L Engine95 L (10.5 qts.)
Automatic Transaxle Service Fill.38 L (4.0 qts.)
Automatic Transaxle 31TH/O-haul Fill80 L (8.5 qts.)
Automatic Transaxle 41TE/O-haul Fill86 L (9.1 qts.)
Power Steering081 L (1.7 pts.)

MAINTENANCE SCHEDULES

INDEX

	page		page
GENERAL INFORMATION		SCHEDULE – B	4
INTRODUCTION	3	UNSCHEDULED INSPECTION	3
SCHEDULE – A	3		

GENERAL INFORMATION

INTRODUCTION

Service and maintenance procedures for components and systems listed in Schedule – A or B can be found by using the Group Tab Locator index at the front of this manual. If it is not clear which group contains the information needed, refer to the index at the back of this manual.

There are two maintenance schedules that show proper service based on the conditions that the vehicle is subjected to.

Schedule – **A**, lists scheduled maintenance to be performed when the vehicle is used for general transportation.

Schedule – **B**, lists maintenance intervals for vehicles that are operated under the conditions listed at the beginning of the Maintenance Schedule section.

Use the schedule that best describes your driving conditions.

Where time and mileage are listed, follow the interval that occurs first.

UNSCHEDULED INSPECTION

At Each Stop for Fuel

- Check engine oil level, add as required.
- Check windshield washer solvent and add if required.

Once a Month

- Check tire pressure and look for unusual wear or damage.
- Inspect battery and clean and tighten terminals as required.
- Check fluid levels of coolant reservoir, brake master cylinder, power steering and transaxle and add as needed.
- Check all lights and all other electrical items for correct operation.
- Check rubber seals on each side of the radiator for proper fit.

At Each Oil Change

- Inspect exhaust system.
- Inspect brake hoses
- Inspect the CV joints and front suspension components
 - Rotate the tires at each oil change interval shown on Schedule – A (7,500 miles) or every other interval shown on Schedule – B (6,000 miles).
 - Check the coolant level, hoses, and clamps.
 - If your mileage is less than 7,500 miles (12 000 km) yearly, replace the engine oil filter at each oil change.
 - Replace engine oil filter on 2.4L engines.

SCHEDULE – A

7,500 Miles (12 000 km) or at 6 months

- Change engine oil.

15,000 Miles (24 000 km) or at 12 months

- Change engine oil.
- Replace engine oil filter.

22,500 Miles (36 000 km) or at 18 months

- Change engine oil.
- Inspect brake linings.

30,000 Miles (48 000 km) or at 24 months

- Change engine oil.
- Change automatic transmission fluid.
- Replace engine oil filter.
- **Replace air cleaner element.**
- Inspect tie rod ends and boot seals.

37,500 Miles (60 000 km) or at 30 months

- Change engine oil.

45,000 Miles (72 000 km) or at 36 months

- Change engine oil.
- Replace engine oil filter.
- Inspect brake linings.
- Flush and replace engine coolant at 36 months, regardless of mileage.

GENERAL INFORMATION (Continued)

52,500 Miles (84 000 km) or at 42 months

- Change engine oil.
- Flush and replace engine coolant if not done at 36 months.

60,000 Miles (96 000 km) or at 48 months

- Change engine oil.
- Replace engine oil filter.
- **Replace air cleaner element.**
- **Check PCV valve and replace, if necessary.**

*

- Inspect serpentine drive belt, replace if necessary.
- Inspect tie rod ends and boot seals.

67,500 Miles (108 000 km) or at 54 months

- Change engine oil.
- Inspect brake linings.

75,000 Miles (120 000 km) or at 60 months

- Change engine oil.
- Replace engine oil filter.
- Inspect serpentine drive belt, replace if necessary. This maintenance is not required if belt was previously replaced.

- Flush and replace engine coolant if it has been 30,000 miles (48 000 km) or 24 months since last change.

82,500 Miles (132 000 km) or at 66 months

- Change engine oil.
- Flush and replace engine coolant if it has been 30,000 miles (48 000 km) or 24 months since last change.

90,000 Miles (144 000 km) or at 72 months

- Change engine oil.
- Replace engine oil filter.
- **Replace air cleaner element.**
- **Check PCV valve and replace, if necessary.**

Not required if previously changed. *

- Inspect serpentine drive belt, replace if necessary. This maintenance is not required if belt was previously replaced.
- Inspect tie rod ends and boot seals.
- Inspect brake linings.

97,500 Miles (156 000 km) or at 78 months

- Change engine oil.

100,000 Miles (160,000 km)

- **Replace spark plugs on 3.3L and 3.8L engines.**
- **Replace ignition cables on 3.3L and 3.8L engines.**

105,000 Miles (168 000 km) or at 84 months

- Change engine oil.
- Replace engine oil filter.
- Inspect serpentine drive belt, replace if necessary. This maintenance is not required if belt was previously replaced.
- Flush and replace engine coolant if it has been 30,000 miles (48 000 km) or 24 months since last change.

112,500 Miles (180 000 km) or at 90 months

- Change engine oil.
- Inspect brake linings.
- Flush and replace engine coolant if it has been 30,000 miles (48 000 km) or 24 months since last change.

120,000 Miles (192 000 km) or at 96 months

- Change engine oil.
- Replace engine oil filter.
- Replace automatic transmission fluid.
- **Replace engine air cleaner element.**
- **Check and replace PCV valve, if necessary.**

*

- Inspect serpentine drive belt. Not required if replaced at 75,000, 90,000 or 105,000 miles.

- Inspect tie rod ends and boot seals.

* This maintenance is recommended by Chrysler to the owner but is not required to maintain the warranty on the PCV valve.

** If California vehicle, this maintenance is recommended by Chrysler to the owner but is not required to maintain the warranty of the timing belt.

SCHEDULE – B

3,000 Miles (5 000 km)

- Change engine oil.

6,000 Miles (10 000 km)

- Change engine oil.
- Replace engine oil filter.

9,000 Miles (14 000 km)

- Change engine oil.
- Inspect brake linings.

12,000 Miles (19 000 km)

- Change engine oil.
- Replace engine oil filter.

15,000 Miles (24 000 km)

- Change engine oil.
- **Inspect air cleaner element. Replace as necessary.**

GENERAL INFORMATION (Continued)

- Drain and refill automatic transmission fluid and replace filter. Adjust bands, if so equipped. (See note)

- Change AWD powertransfer fluid unit.

18,000 Miles (29 000 km)

- Change engine oil.
- Replace engine oil filter.
- Inspect brake linings.

21,000 Miles (34 000 km)

- Change engine oil.
- Check AWD overrunning clutch and rear carrier fluid.

24,000 Miles (38 000 km)

- Change engine oil.
- Replace engine oil filter.

27,000 Miles (43 000 km)

- Change engine oil.
- Inspect brake linings.

30,000 Miles (48 000 km)

- Change engine oil.
- Replace engine oil filter.
- **Replace air cleaner element.**
- **Inspect PCV valve. Replace as necessary. ***
- Drain and refill automatic transmission fluid and replace filter. Adjust bands, if so equipped. (See note)
- Change AWD power transfer unit fluid.
- Inspect tie rod ends and boot seals.

33,000 Miles (53 000 km)

- Change engine oil.

36,000 Miles (58 000 km)

- Change engine oil.
- Replace engine oil filter.
- Inspect brake linings.

39,000 Miles (62 000 km)

- Change engine oil.

42,000 Miles (67 000 km)

- Change engine oil.
- Replace engine oil filter.
- Change AWD overrunning clutch and rear carrier fluid.

45,000 Miles (72 000 km)

- Change engine oil.
- **Inspect air cleaner element. Replace as necessary.**

- Drain and refill automatic transmission fluid and replace filter. Adjust bands, if so equipped. (See note)

- Inspect brake linings.
- Change AWD power transfer unit fluid.

48,000 Miles (77 000 km)

- Change engine oil.
- Replace engine oil filter.

51,000 Miles (82 000 km)

- Change engine oil.
- Flush and replace engine coolant.

54,000 Miles (86 000 km)

- Change engine oil.
- Replace engine oil filter.
- Inspect brake linings.

57,000 Miles (91 000 km)

- Change engine oil.

60,000 Miles (96 000 km)

- Change engine oil.
- Replace engine oil filter.
- **Replace air cleaner element.**
- **Inspect PCV valve, replace if necessary. ***
- Inspect serpentine drive belt, replace if necessary.
- Drain and refill automatic transmission fluid and replace filter. Adjust bands, if so equipped. (See note)
- Change AWD power transfer unit fluid.
- Inspect tie rod ends and boot seals.

63,000 Miles (101 000 km)

- Change engine oil.
- Change AWD overrunning clutch and rear carrier fluid.
- Inspect brake linings.

66,000 Miles (106 000 km)

- Change engine oil.
- Replace engine oil filter.

69,000 Miles (110 000 km)

- Change engine oil.

72,000 Miles (115 000 km)

- Change engine oil.
- Replace engine oil filter.
- Inspect brake linings.

75,000 Miles (120 000 km)

- Change engine oil.
- **Inspect air cleaner element. Replace as necessary.**

GENERAL INFORMATION (Continued)

- **Replace spark plugs.**
- **Replace ignition cables.**
- Inspect serpentine drive belt, replace if necessary. This maintenance is not required if belt was previously replaced.
- Drain and refill automatic transaxle fluid and replace filter. Adjust band, if so equipped. (See note)
- Change AWD power transfer unit fluid.

78,000 Miles (125 000 km)

- Change engine oil.
- Replace engine oil filter.

81,000 Miles (130 000 km)

- Change engine oil.
- Inspect brake linings.
- Flush and replace engine coolant.

84,000 Miles (134 000 km)

- Change engine oil.
- Replace engine oil filter.
- Change AWD overrunning clutch and rear carrier fluid.

87,000 Miles (139 000 km)

- Change engine oil.

90,000 Miles (144 000 km)

- Change engine oil.
 - Replace engine oil filter.
 - **Replace air cleaner element.**
 - **Check PCV valve and replace if necessary.** *
- Not required if previously changed. ***
- Inspect serpentine drive belt, replace if necessary. This maintenance is not required if belt was previously replaced.
 - Drain and refill automatic transmission fluid and replace filter. Adjust bands, if so equipped. (See note)
 - Change AWD power transfer unit fluid.
 - Inspect tie rod ends and boot seals.
 - Inspect brake linings.

93,000 Miles (149 000 km)

- Change engine oil.

96,000 Miles (154 000 km)

- Change engine oil.
- Replace engine oil filter.

99,000 Miles (158 000 km)

- Change engine oil.
- Inspect brake linings.

102,000 Miles (163 000 km)

- Change engine oil.
- Replace engine oil filter.

105,000 Miles (168 000 km)

- Change engine oil.
- **Inspect air cleaner element. Replace as necessary.**
- Inspect serpentine drive belt, replace if necessary. This maintenance is not required if belt was previously replaced.
- Drain and refill automatic transmission fluid and filter. Adjust bands, if so equipped. (See note)
- Change AWD power transfer unit fluid.
- Change AWD overrunning clutch and rear carrier fluid.

108,000 Miles (173 000 km)

- Change engine oil.
- Replace engine oil filter.
- Inspect brake linings.

111,000 Miles (178 000 km)

- Change engine oil.
- Flush and replace engine coolant.

114,000 Miles (182 000 km)

- Change engine oil.
- Replace engine oil filter.

117,000 Miles (187 000 km)

- Change engine oil.
- Inspect brake linings.

120,000 Miles (192 000 km)

- Change engine oil.
 - Replace engine oil filter.
 - **Replace air cleaner element.**
 - **Inspect PCV valve. Replace as necessary. ***
 - Inspect serpentine drive belt. Not required if replaced at 75,000, 90,000 or 105,000 miles.
 - Drain and refill automatic transmission fluid and replace filter. Adjust bands, if so equipped.
 - Change AWD power transfer unit fluid.
 - Inspect tie rod ends and boot seals.
- * This maintenance is recommended by Chrysler to the owner but is not required to maintain the warranty on the PCV valve.
- ** If California vehicle, this maintenance is recommended by Chrysler to the owner but is not required to maintain the warranty of the timing belt.

NOTE: Operating vehicle more than 50% in heavy traffic during hot weather, above 90°F (32°C), using vehicle for police, taxi, limousine type operation or trailer towing require the more frequent transaxle service noted in Schedule – B. Perform these services if vehicle is usually operated under these conditions.

Inspection and service should also be performed anytime a malfunction is observed or suspected.

JUMP STARTING, HOISTING AND TOWING

INDEX

	page		page
SERVICE PROCEDURES		JUMP STARTING PROCEDURE	7
HOISTING RECOMMENDATIONS	9	TOWING RECOMMENDATIONS	8

SERVICE PROCEDURES

JUMP STARTING PROCEDURE

WARNING: REVIEW ALL SAFETY PRECAUTIONS AND WARNINGS IN GROUP 8A, BATTERY/STARTING/CHARGING SYSTEMS DIAGNOSTICS. DO NOT JUMP START A FROZEN BATTERY, PERSONAL INJURY CAN RESULT. DO NOT JUMP START WHEN MAINTENANCE FREE BATTERY INDICATOR DOT IS YELLOW OR BRIGHT COLOR. DO NOT JUMP START A VEHICLE WHEN THE BATTERY FLUID IS BELOW THE TOP OF LEAD PLATES. DO NOT ALLOW JUMPER CABLE CLAMPS TO TOUCH EACH OTHER WHEN CONNECTED TO A BOOSTER SOURCE. DO NOT USE OPEN FLAME NEAR BATTERY. REMOVE METALLIC JEWELRY WORN ON HANDS OR WRISTS TO AVOID INJURY BY ACCIDENTAL ARCING OF BATTERY CURRENT. WHEN USING A HIGH OUTPUT BOOSTING DEVICE, DO NOT ALLOW BATTERY VOLTAGE TO EXCEED 16 VOLTS. REFER TO INSTRUCTIONS PROVIDED WITH DEVICE BEING USED.

CAUTION: When using another vehicle as a booster, do not allow vehicles to touch. Electrical systems can be damaged on either vehicle.

TO JUMP START A DISABLED VEHICLE:

- (1) Raise hood on disabled vehicle and visually inspect engine compartment for:
 - Battery cable clamp condition, clean if necessary.
 - Frozen battery.
 - Yellow or bright color test indicator, if equipped.
 - Low battery fluid level.
 - Generator drive belt condition and tension.
 - Fuel fumes or leakage, correct if necessary.

CAUTION: If the cause of starting problem on disabled vehicle is severe, damage to booster vehicle charging system can result.

- (2) When using another vehicle as a booster source, park the booster vehicle within cable reach. Turn off all accessories, set the parking brake, place

the automatic transmission in PARK or the manual transmission in NEUTRAL and turn the ignition OFF.

- (3) On disabled vehicle, place gear selector in park or neutral and set park brake. Turn off all accessories.

- (4) Connect jumper cables to booster battery. RED clamp to positive terminal (+). BLACK clamp to negative terminal (-). DO NOT allow clamps at opposite end of cables to touch, electrical arc will result. Review all warnings in this procedure.

- (5) On disabled vehicle, connect RED jumper cable clamp to positive (+) terminal. Connect BLACK jumper cable clamp to engine ground as close to the ground cable attaching point as possible (Fig. 1).

- (6) Start the engine in the vehicle which has the booster battery, let the engine idle a few minutes, then start the engine in the vehicle with the discharged battery.

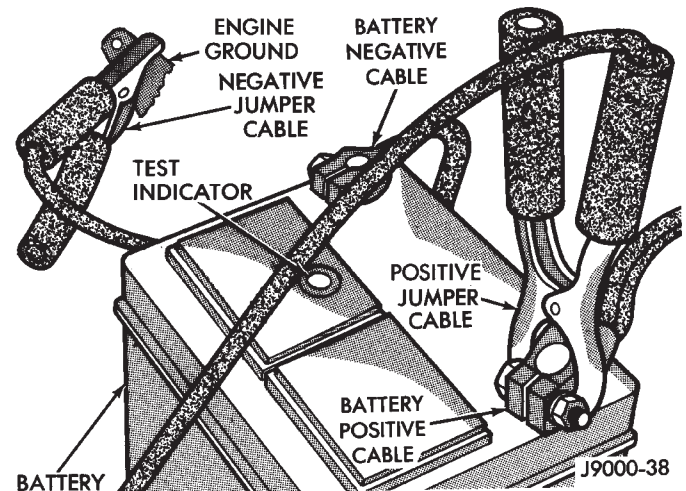

Fig. 1 Jumper Cable Clamp Connections

CAUTION: Do not crank starter motor on disabled vehicle for more than 15 seconds, starter will overheat and could fail.

- (7) Allow battery in disabled vehicle to charge to at least 12.4 volts (75% charge) before attempting to start engine. If engine does not start within 15 seconds, stop cranking engine and allow starter to cool (15 min.), before cranking again.

SERVICE PROCEDURES (Continued)

DISCONNECT CABLE CLAMPS AS FOLLOWS:

- Disconnect BLACK cable clamp from engine ground on disabled vehicle.
- When using a Booster vehicle, disconnect BLACK cable clamp from battery negative terminal. Disconnect RED cable clamp from battery positive terminal.
- Disconnect RED cable clamp from battery positive terminal on disabled vehicle.

TOWING RECOMMENDATIONS

WARNINGS AND CAUTIONS

WARNING: DO NOT ALLOW TOWING ATTACHMENT DEVICES TO CONTACT THE FUEL TANK OR LINES, FUEL LEAK CAN RESULT.

DO NOT LIFT OR TOW VEHICLE BY FRONT OR REAR BUMPER, OR BUMPER ENERGY ABSORBER UNITS.

DO NOT GO UNDER A LIFTED VEHICLE IF NOT SUPPORTED PROPERLY ON SAFETY STANDS.

DO NOT ALLOW PASSENGERS TO RIDE IN A TOWED VEHICLE.

USE A SAFETY CHAIN THAT IS INDEPENDENT FROM THE TOWING ATTACHMENT DEVICE.

CAUTION: Do not damage brake lines, exhaust system, shock absorbers, sway bars, or any other under vehicle components when attaching towing device to vehicle.

Do not attach towing device to front or rear suspension components.

Do not secure vehicle to towing device by the use of front or rear suspension or steering components.

Remove or secure loose or protruding objects from a damaged vehicle before towing.

Refer to state and local rules and regulations before towing a vehicle.

Do not allow weight of towed vehicle to bear on lower fascia, air dams, or spoilers.

RECOMMENDED TOWING EQUIPMENT

To avoid damage to bumper fascia and air dams use of a flat bed towing device or wheel lift (Fig. 2) is recommended. When using a wheel lift towing device, be sure the disabled vehicle has at least 100 mm (4 in.) ground clearance. If minimum ground clearance cannot be reached, use a towing dolly. If a flat bed device is used, the approach angle should not exceed 15 degrees.



WHEEL LIFT

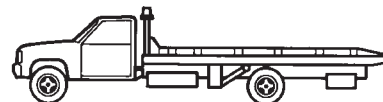

FLAT BED

9100-17

Fig. 2 Recommended Towing Devices

GROUND CLEARANCE

CAUTION: If vehicle is towed with wheels removed, install lug nuts to retain brake drums or rotors.

A towed vehicle should be raised until the lifted wheels are a minimum 100 mm (4 in.) from the ground. Be sure there is at least 100 mm (4 in.) clearance between the tail pipe and the ground. If necessary, remove the wheels from the lifted end of the vehicle and lower the vehicle closer to the ground, to increase the ground clearance at the rear of the vehicle. Install lug nuts on wheel attaching studs to retain brake drums or rotors.

LOCKED VEHICLE TOWING

When a locked vehicle must be towed with the front wheels on the ground, use a towing dolly or flat bed hauler.

FLAT TOWING WITH TOW BAR

- 3-speed automatic transaxle vehicles can be flat towed at speeds not to exceed 40 km/h (25 mph) for not more than 25 km (15 miles). The steering column must be unlocked and gear selector in neutral.

- 4-speed electronic automatic transaxle vehicles can be flat towed at speeds not to exceed 72 km/h (44 mph) for not more than 160 km (100 miles). The steering column must be unlocked and gear selector in neutral.

FLAT BED TOWING TIE DOWNS

CAUTION: Do not tie vehicle down by attaching chains or cables to suspension components or engine mounts, damage to vehicle can result.

NS vehicles can be tied to a flat bed device using the reinforced loops located under the front and rear bumpers on the drivers side of the vehicle. There are also four reinforced elongated holes for T or R-hooks located on the bottom of the front frame rail torque

SERVICE PROCEDURES (Continued)

boxes behind the front wheels and forward of the rear wheels inboard of the rocker panel weld seam.

TOWING—FRONT WHEEL LIFT

Chrysler Corporation recommends that a vehicle be towed with the front end lifted, whenever possible. A 90 cm (36 in.) length of 4x4 wood beam can be placed between the wheel lift device and the bottom of the fascia to prevent damage to vehicle during the lifting operation. The beam can be removed after lifting the front of the vehicle.

TOWING—REAR WHEEL LIFT

If a vehicle cannot be towed with the front wheels lifted, the rear wheels can be lifted provided the following guide lines are observed.

CAUTION: Do not use steering column lock to secure steering wheel during towing operation.

- On AWD vehicles, all four wheels must be free to rotate. Use towing dollies at unlifted end of vehicle.
- Unlock steering column and secure steering wheel in straight ahead position with a clamp device designed for towing.
- 3-speed automatic transaxle vehicles can be flat towed at speeds not to exceed 40 km/h (25 mph) for not more than 25 km (15 miles). The steering column must be unlocked and gear selector in neutral.
- 4-speed electronic automatic transaxle vehicles can be flat towed at speeds not to exceed 72 km/h (44 mph) for not more than 160 km (100 miles). The steering column must be unlocked and gear selector in neutral.

HOISTING RECOMMENDATIONS

Refer to Owner's Manual provided with vehicle for proper emergency jacking procedures.

WARNING: THE HOISTING AND JACK LIFTING POINTS PROVIDED ARE FOR A COMPLETE VEHICLE. WHEN THE ENGINE OR REAR SUSPENSION IS REMOVED FROM A VEHICLE, THE CENTER OF GRAVITY IS ALTERED MAKING SOME HOISTING CONDITIONS UNSTABLE. PROPERLY SUPPORT OR

SECURE VEHICLE TO HOISTING DEVICE WHEN THESE CONDITIONS EXIST.

CAUTION: Do not position hoisting device on suspension components or front crossmember, damage to vehicle can result.

TO HOIST OR JACK VEHICLE SEE (Fig. 3).

Vehicles with factory installed ground effects are equipped with front and rear hoisting pads. These pads are stamped, "Hoist Point".

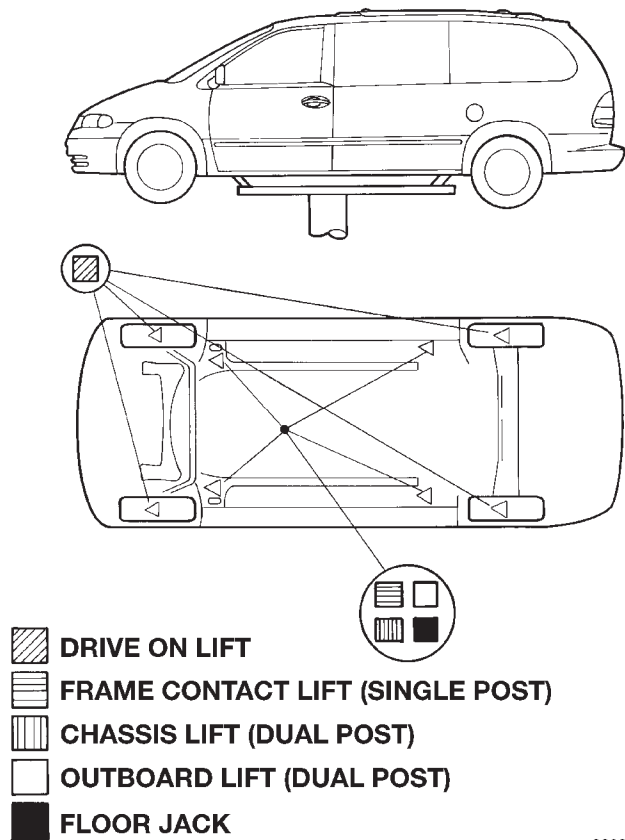

8008a54d

Fig. 3 HOISTING AND JACKING POINTS

